



The Mark of Reliability

(Est. 1930)

Customised commercial water control products and machined casting services

GE PRE-RINSE UNITS HOB MOUNTED MODELS TF80H, TF81H TF82H, TF83H & TF84H

INSTALLATION AND OPERATING INSTRUCTIONS



Hand Piece

Specifications:

- Galvin Engineering recommends the installation of strainers and pressure reducing valves prior to the Pre-Rinse unit to ensure clean consistent supply. Debris or poor water quality could cause the trigger to cease or fail to seal.
- Whilst GE Pre-Rinse units have a 6 star WELS rating, the pot filler attachments are 0 star to allow fast pot filling.
- The identification buttons on the handles are standard and signify hot or cold water only. If water other than hot or cold is used (e.g. pre-mixed) then appropriate identification buttons will need to be purchased to replace those supplied on the standard unit.
- The hose on these units is not suitable for potable water and should only be used for washing down.
- The recommended maximum operating conditions are 65° C and 500 KPa (70 PSI). Higher temperatures or pressures could result in premature failure and void the manufacturer's warranty.

Installation:

(To be read in conjunction with the general arrangement drawing).

1. If the mounting holes do not already exist, mark out and drill the hole/s in the bench/trough to suit the required model as shown in Fig. 1 page 3
 - Models TF80H and TF81H are single inlet units requiring a hole diameter of 23-26mm.
 - Model TF82H is a dual inlet concealed unit requiring hole diameters of 31-35mm, between 120mm and 255mm apart, with a hole in the centre of diameter 25-28mm. This model is typically installed into Three Tap Hole basin or sink.
 - Model TF83H is a dual inlet unit requiring hole diameters of 23-26mm, 205mm apart.
 - Model TF84H is a single inlet unit requiring a hole diameter of 31-35mm.

GALVIN ENGINEERING PTY LTD - ABN: 78 008 719 382

WA Head Office - Perth
410 Victoria Rd Malaga WA 6090
PO Box 2063 Malaga WA 6944
Phone: 61 (0)8 9249 5900
Fax: 61 (0)8 9249 5916
Email: galvin@galvinengineering.com.au

NSW Branch - Sydney
19/115-123 Woodpark Road
Smithfield NSW 2164
Phone: 61 (0)2 9681 1366
Fax: 61 (0)2 9681 1477
Email: nsw@galvinengineering.com.au

QLD Branch - Brisbane
9/36 Blanck Street
Ormeau QLD 4209
Phone: 61 (0)7 5540 7467
Fax: 61 (0)7 5540 7542
Email: qld@galvinengineering.com.au

VIC Branch - Melbourne
11, 314 Governor Road
Braeside VIC 3195
Phone: 61 (0)3 9580 6622
Fax: 61 (0)3 9580 4144
Email: vic@galvinengineering.com.au



GALVIN ENGINEERING
www.galvinengineering.com.au





The Mark of Reliability

(Est. 1930)

Customised commercial water control products and machined casting services

2. If a TF82H unit with concealed basin set is being installed, then the basin set needs to be installed at this point. Do not fit the Hob base, but ensure the hob base backnut is sitting loosely on the breech piece prior to installation.
3. Mark out the three (3) holes for mounting the Wall Bracket Assembly, at a height less than 'A' as shown in Fig 1. Drill the three (3) holes to suit the fasteners supplied (The fasteners may not be appropriate for all wall materials. If this is the case, other fastening systems will have to be sourced by the installer).

Note: The wall bracket can be mounted at a height of up to 90mm below the circlip, however the further it is mounted away from the circlip, the more the stability of the unit is compromised.

4. Measure the distance 'B' between the wall and the centre of the hole/s that have been drilled in the bench/trough. Subtract 17mm from the measured distance, and then cut the Extension Rod in Fig 2 to that length as shown. **DO NOT** cut off the threaded end. (Note: Distance 'B' must be no less than 50mm. If it is more than 290mm, then an extended Extension Rod must be purchased).
5. Fit the Wall Flange to the wall, as shown in Fig. 2.
6. If the Pot Filler Kit has been purchased, it must be attached to the pre rinse unit now. Refer to the Installation and operating instructions supplied with the Pot Filler
7. Screw the Wall Bracket Extension Rod into the Hand Spray Holder Ring (see Fig 2) but do not tighten (The Hand Spray Holder Ring can be found already pre-fitted to the pre-rinse unit body).
8. Fit the Pre-Rinse Unit Body into the bench/trough, then fit the Extension Rod into the wall flange. Ensure that the rubber washer/s are fitted to the top of the bench/trough and tighten the lock nut/s.
9. Tighten the Extension Rod into the Hand Spray Holder Ring, then tighten the two grub screws in the wall flange with the Allen key supplied. **These grub screws must be tightened firmly to ensure they dig into the extension rod, otherwise the rod will pull out when in use.** The Wall Bracket is now rigid.
10. Slide the Black Plastic Sleeve over the Body, resting it on the Circlip.
11. Attach the spring assembly to the body of the unit, making sure to utilise the supplied fibre washer. Once the hose nut is secured to the body, slide the Spring over the hose nut and the Black Plastic Sleeve.
12. Once fitting is completed and the unit has been connected to the mains water, the unit must be tested for any leaks.

OPERATING INSTRUCTIONS

- The isolation or mixing taps must be turned OFF whilst the unit is not in use, so that the unit is not under mains pressure when unsupervised. Flood damage may occur if a failure occurs whilst the unit is under mains pressure. (The warranty is void in this instance).
- Galvin Engineering recommends that the handpiece be removed periodically for servicing by a qualified plumber.

GALVIN ENGINEERING PTY LTD - ABN: 78 008 719 382

WA Head Office - Perth
410 Victoria Rd Malaga WA 6090
PO Box 2063 Malaga WA 6944
Phone: 61 (0)8 9249 5900
Fax: 61 (0)8 9249 5916
Email: galvin@galvinengineering.com.au

NSW Branch - Sydney
19/115-123 Woodpark Road
Smithfield NSW 2164
Phone: 61 (0)2 9681 1366
Fax: 61 (0)2 9681 1477
Email: nsw@galvinengineering.com.au

QLD Branch - Brisbane
9/36 Blanck Street
Ormeau QLD 4209
Phone: 61 (0)7 5540 7467
Fax: 61 (0)7 5540 7542
Email: qld@galvinengineering.com.au

VIC Branch - Melbourne
11, 314 Governor Road
Braeside VIC 3195
Phone: 61 (0)3 9580 6622
Fax: 61 (0)3 9580 4144
Email: vic@galvinengineering.com.au



GALVIN ENGINEERING
www.galvinengineering.com.au





The Mark of Reliability

(Est. 1930)

Customised commercial water control products and machined casting services

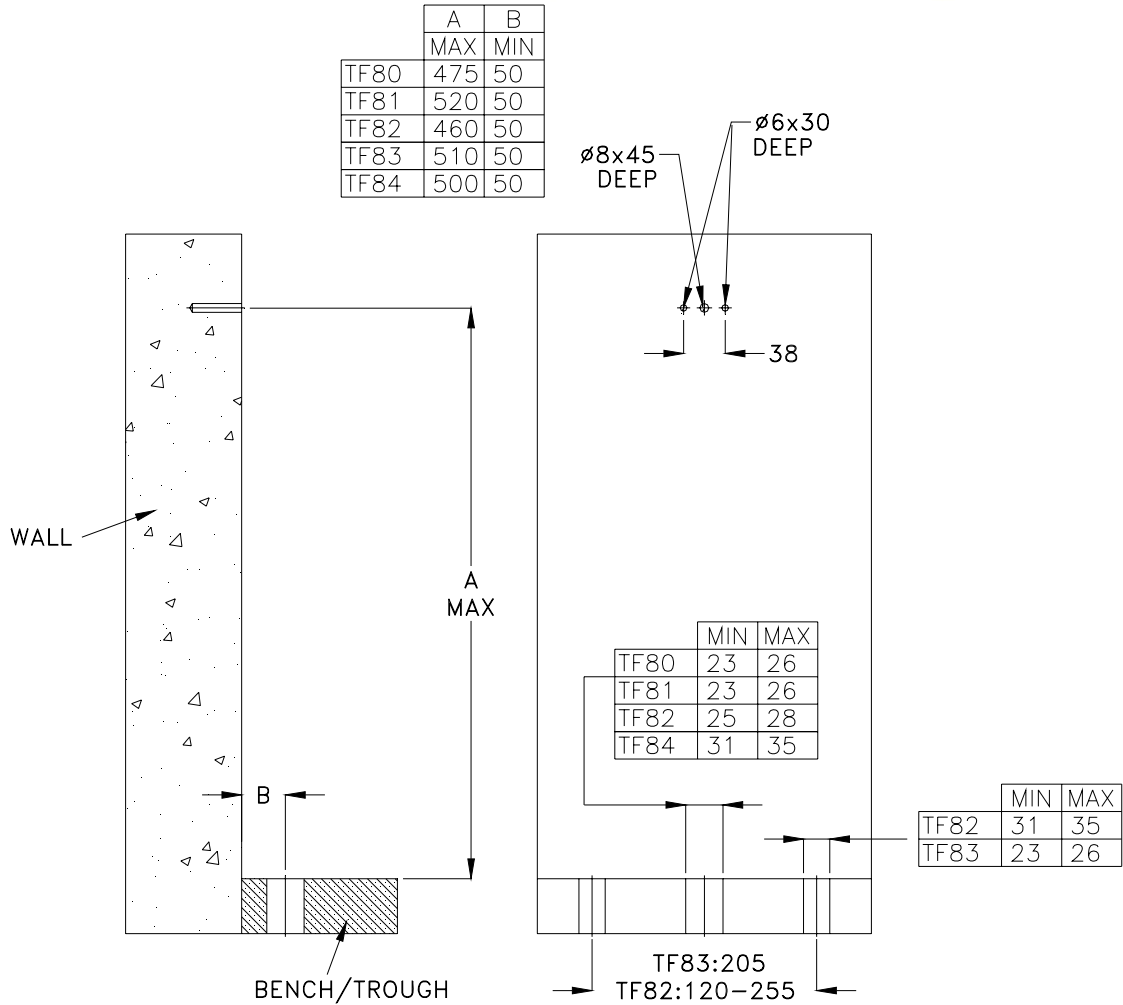

Figure 1 – Mounting detail for Hob Mounted Pre-Rinse Unit

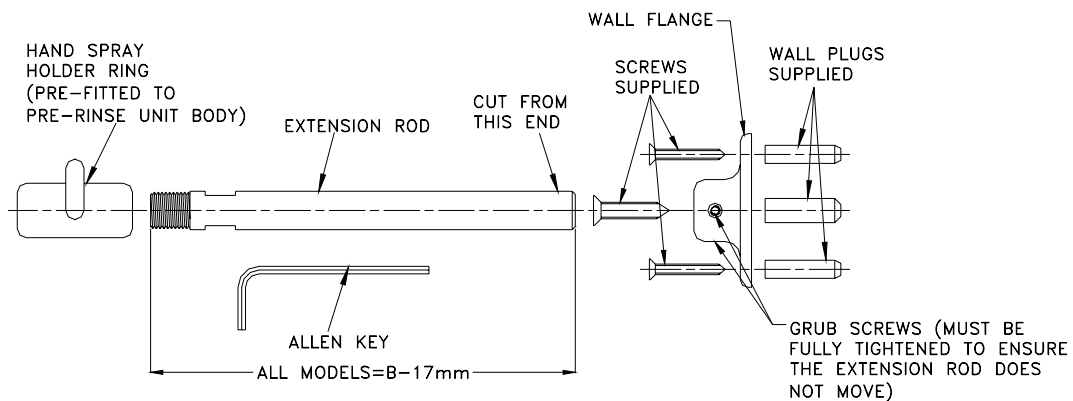

Figure 2 – Wall Bracket Assembly Adjustable (40 – 285 mm)

GALVIN ENGINEERING PTY LTD - ABN: 78 008 719 382

WA Head Office - Perth
 410 Victoria Rd Malaga WA 6090
 PO Box 2063 Malaga WA 6944
 Phone: 61 (0)8 9249 5900
 Fax: 61 (0)8 9249 5916
 Email: galvin@galvinengineering.com.au

NSW Branch - Sydney
 19/115-123 Woodpark Road
 Smithfield NSW 2164
 Phone: 61 (0)2 9681 1366
 Fax: 61 (0)2 9681 1477
 Email: nsw@galvinengineering.com.au

QLD Branch - Brisbane
 9/36 Blanck Street
 Ormeau QLD 4209
 Phone: 61 (0)7 5540 7467
 Fax: 61 (0)7 5540 7542
 Email: qld@galvinengineering.com.au

VIC Branch - Melbourne
 11, 314 Governor Road
 Braeside VIC 3195
 Phone: 61 (0)3 9580 6622
 Fax: 61 (0)3 9580 4144
 Email: vic@galvinengineering.com.au



GALVIN ENGINEERING

www.galvinengineering.com.au



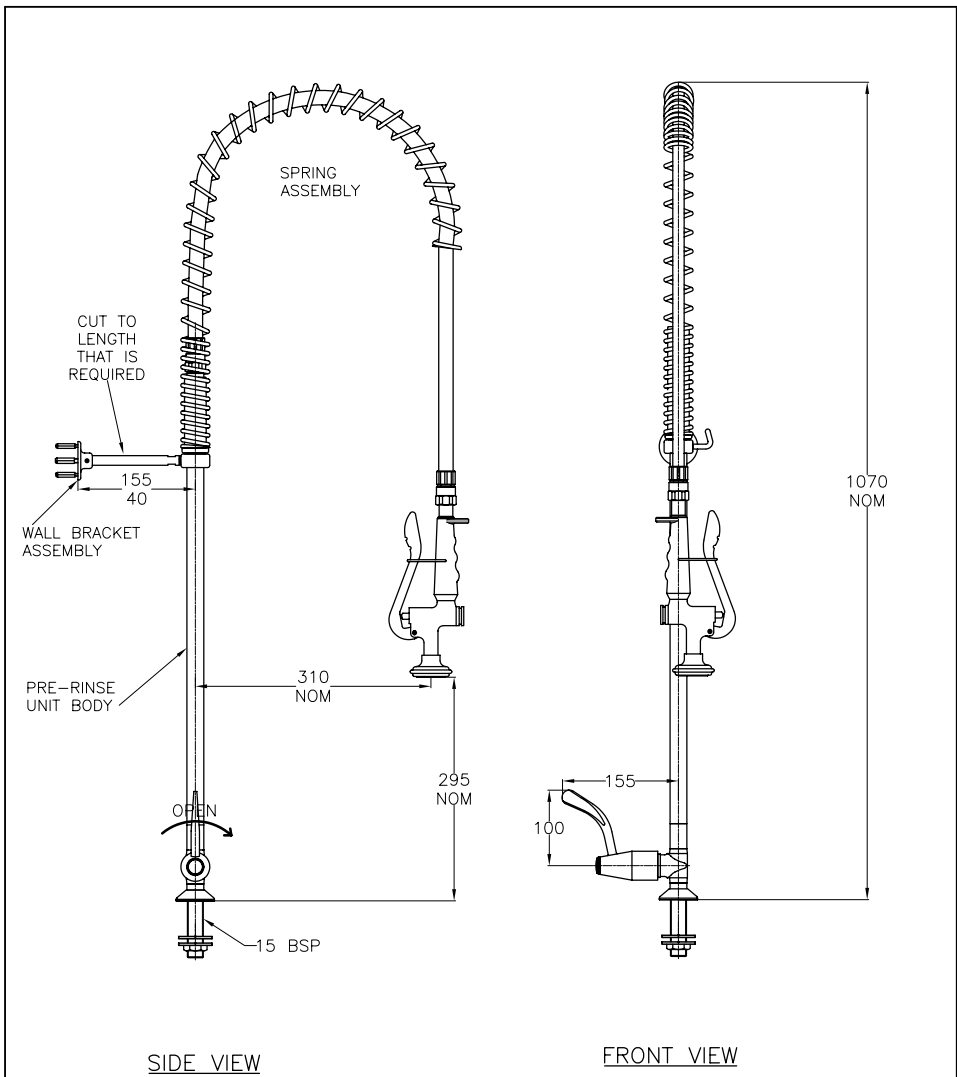

SIDE VIEW

FRONT VIEW

DRAWING CURRENT AT TIME OF ISSUE BUT SUBJECT TO REVISION WITHOUT NOTIFICATION

MATERIAL: # © COPYRIGHT RESERVED <small>THE INFORMATION ON THIS DRAWING IS THE PROPERTY OF GALVIN ENGINEERING. IT IS TO BE USED ONLY FOR THE PROJECT AND QUANTITY SPECIFIED. IT IS NOT TO BE REPRODUCED, COPIED OR TRANSMITTED IN ANY FORM OR BY ANY MEANS, ELECTRONIC OR MECHANICAL, INCLUDING PHOTOCOPYING, RECORDING, OR BY ANY INFORMATION STORAGE AND RETRIEVAL SYSTEM. WITHOUT THE WRITTEN PERMISSION OF GALVIN ENGINEERING.</small>		FINISH C/P UNLESS OTHERWISE STATED ALL DIMENSIONS IN MM TOLERANCES X ±1.0 .X ±0.1 .XX ±0.05	IF IN DOUBT ASK DWG S. DAVEY 28/3/04 DTD P/JG MANUFACTURED TO AS N/A SCALE NOT TO SCALE ISSUED TF	TITLE GE CP HOB MTD SINGLE STOP PRE-RINSE UNIT TYPE 81H, 15 BSP MI INLET-STANDARD MANUFACTURED TO AS N/A SCALE NOT TO SCALE SHEET 2 OF 2	DRAWING NO TF81HJS
REVISION:	REV DESCRIPTION DATE APPD				