



285122

Ductile Iron Hi-Flow Flat Grate Vertical Rain Water Outlet (with Membrane Clamp Ring) 150 BSP

Specifications

Ductile iron grey enamel coated rain water drain with built in puddle flange and galvanised ductile iron flat grate, clamp ring and lock down screws.

Features

- Removable grate for ease of access, without disturbing the puddle flange and clamp ring.
- Roof drain body suits our standard PVC/HDPE adjustable adaptor.
- Large open area of the grate permits unrestricted water flow.
- Ductile iron grate as per 150 1083/55/500-7/J to AS 1831.
- Certified by the AHSCA Research Foundation.

Typical Dimension

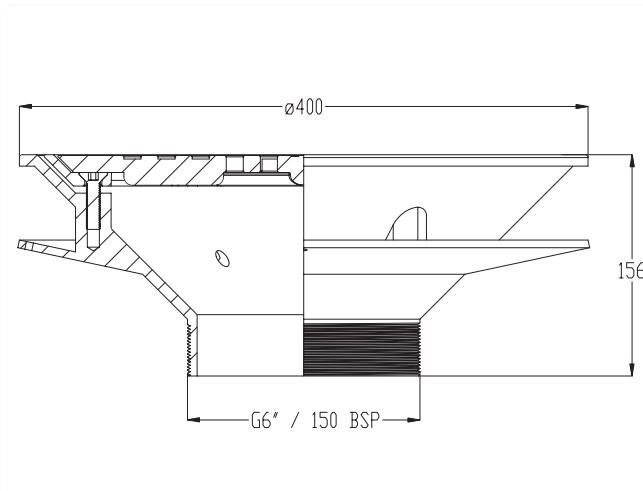

Application

The flat grate version clamp ring type outlet is designed to hold a bituminous membrane between the body and the clamp ring. When removing the grate for cleaning purposes, the clamp ring remains in position leaving the membrane undisturbed. This assures a watertight seal at all times. In addition, any water seepage around the outlet is trapped at the base of the built in puddle flange and is discharged through the weep holes into the drain. This prevents moisture penetrating to lower level. The puddle flange type outlet is primarily designed for concrete floors where a membrane is fitted (e.g. Large concrete roofs and test areas).

Flow Rate Guide (Litres/Second):

Inlet Size	Outlet Size	Pressure Head mm of Water				
		18mm	30mm	40mm	50mm	100mm
400	150	5.0	10.0	15.0	20.0	28.0

Typical Installation

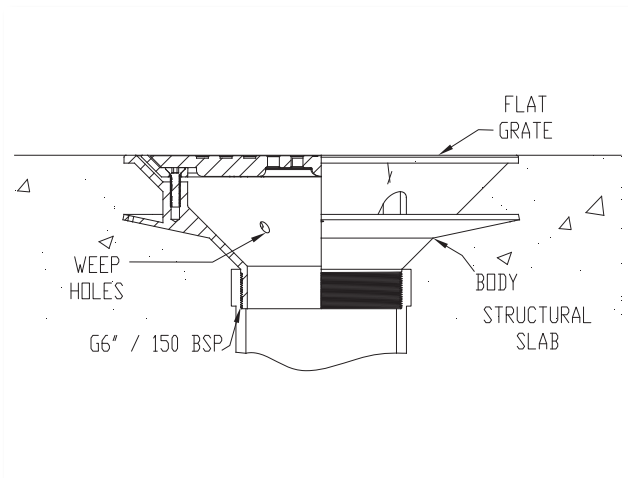

Maintenance & Cleaning

Red Emperor products should be cleaned with a soft damp cloth using only mild liquid detergent or soap and water. Do not use cleaning agents containing a corrosive acid, scouring agent or solvents. Do not use cream cleaners, as they are abrasive. Use of unsuitable cleaning agents may damage the surface. Any damage caused in this way will not be covered by warranty.

Regular maintenance should be carried out in accordance with installation and troubleshooting guides provided with the product, the relevant Australian Standards, local authorities and state codes.

Tea staining is an installation and maintenance issue. To reduce the risk of tea staining, products should be regularly cleaned. In certain environments corrosion reducers/inhibitors may need to be regularly applied, and consideration should be given to the use of electropolishing or other surface coatings.

Note: It is recommended higher grades of stainless steel be specified for corrosive or coastal areas.

Warranty

Red Emperor products are covered under our Manufacturer's Warranty at www.galvinengineering.com.au. Red Emperor products must be installed in accordance with the installation instructions and in accordance with AS3500, PCA, relevant Australian Standards and local authorities applicable to product being installed. Water and electrical supply conditions must also comply to the applicable national and/or state standards, failing to comply with these provisions may void the product warranty and affect performance of the product.

Whilst all reasonable care has been taken in compiling the information in this document, the designs, dimensions and products shown are indicative only and should not be relied upon without our prior approval. Due to our policy of continuous development, we reserve the right to alter any details of specifications or products without notice. All information, drawings, technical specifications and product designs remains the property of Galvin Engineering Pty Ltd.

Within Australia: **1300 514 074** Outside Australia: P: +61 (0)8 9338 2344
 F: +61 (0)8 9338 2340
sales@galvinengineering.com.au
www.galvinengineering.com.au

ABN: 78 008 719 382

PERTH | SYDNEY | MELBOURNE | BRISBANE | ADELAIDE

GalvinEngineering 
the mark of reliability