

Galvin Ultra GM20 Infrared Hob Basin Tap Single Temperature - Battery Operated

Specification Data Sheet



Features

- Sturdy modular one piece design.
- Dual infrared sensors with automatic setting feature, microprocessor-electronic.
- Reliable solenoid valve.
- Vandal-resistant aerator Cold water supply connection with flexible high pressure hose.
- Built in filters with integrated automatic shut-off for facilitate replacing or cleaning the filter.
- One tool service all key components are easily accessible from above the basin.
- 12 or 24 hour hygienic rinse activated with Touch.
- External battery box.

To Specify

The Galvin Ultra GM Series of chrome plated sensor tapware offers superior performance in any commercial or private restroom. Its hands free operation provides users a hygienic handwashing experience while reducing water and energy consumption.

Code:

TZ-GM20SB – Galvin Ultra GM20 Infrared Hob Basin Tap 178mm Single Temperature - Battery Operated



A family
owned
Australian
business



galvin'sspecialised
commercial taps + fixtures

Performance Standards & Approvals

- AS/NZS 3718 WaterMark
- WELS 6 Star Rating



Typical Dimensions

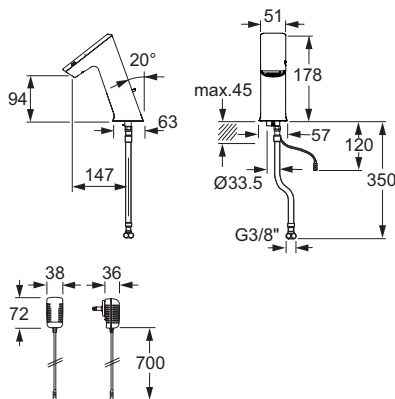

Typical Installation

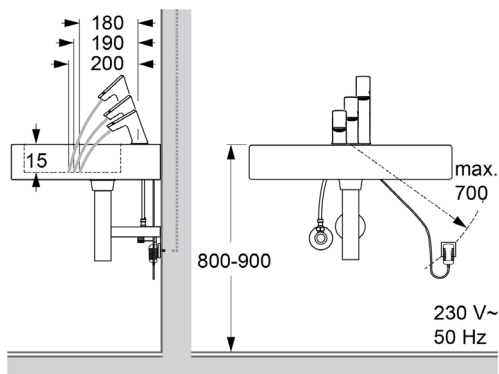

Operation

As the user's hands enter the beam's effective range, the beam is reflected back into the sensor receiver and activates the solenoid valve allowing water to flow from the tap. Water will flow until the hands are removed or until the tap reaches its automatic time out limit setting.

Whilst all reasonable care has been taken in compiling the information in this document, the designs, dimensions and products shown are indicative only and should not be relied upon without our prior approval. Due to our policy of continuous development, we reserve the right to alter any details of specifications or products without notice. All information, drawings, technical specifications and product designs remains the property of Galvin Engineering Pty Ltd.

Technical Information

- Operating pressure: 30kPa - 500kPa
- Maximum water temperature: 80°C
- Aerator: Aerator RC
- Filters: 0.5mm mesh size
- Sensor sensitivity: Automatic self-adapting sensor technology
- Follow-up time: 1 second pre-set (adjustable with touch 0-10 seconds)
- Continuous water flow and hygienic rinse time: 2 minutes pre-set (adjustable with Touch 0.5-20 minutes)
- Temporary-off: 2 minute (fixed)
- Power Supply: 3 x 1.5V Alkaline batteries
- Engineering standards: DIN EN 200; CE

Maintenance & Cleaning

Galvin Specialised products should be cleaned with a soft damp cloth using only mild liquid detergent or soap and water. Do not use cleaning agents containing a corrosive acid, scouring agent or solvents. Do not use cream cleaners, as they are abrasive. Use of unsuitable cleaning agents may damage the surface. Any damage caused in this way will not be covered by warranty.

Regular maintenance should be carried out in accordance with the installation and troubleshooting guides provided with the product, relevant Australian Standards, local authorities and state codes.

As part of maintaining a safe and reliable plumbing system, we recommend tapware and valves are operated on at least a daily basis.

Warranty

Galvin Specialised products are covered under our Manufacturer's Warranty at www.galvinengineering.com.au. Galvin Specialised products must be installed in accordance with the installation instructions and in accordance with AS3500 and the PCA, relevant Australian Standards and local authorities applicable to product being installed. Water and electrical supply conditions must also comply to the applicable national and/or state standards, failing to comply with these provisions may void the product warranty and affect performance of the product.

Within Australia: **1300 514 074** Outside Australia: P: +61 (0)8 9338 2344

F: +61 (0)8 9338 2340

sales@galvinengineering.com.au

www.galvinengineering.com.au

ABN: 78 008 719 382

PERTH | SYDNEY | MELBOURNE | BRISBANE | ADELAIDE

GalvinEngineering 
the mark of reliability