

CliniMix® Inwall Thermostatic Progressive Shower Mixer with GalvinCare® Handle - Warm & Cold

Specification Data Sheet



Features

- The first Australian approved progressive mixer with an inbuilt thermal disinfection facility, helping to minimise bacteria build up (kit sold separately)
- Has unique thermal disinfection bypass feature
- Reduces risk of Legionella growth by mixing water close to point of discharge and minimising stagnant warm water
- Minimises dirt build up and is fast and easy to clean due to its smooth internal and external design
- Can be set to thermostatically controlled water temperature of 48°C
- Water flow always starts from cold for safe usage
- All servicing and commissioning can be done without removing the device. Easy accessible isolators help minimising time for commissioning and maintenance
- Rapid shut down in event of cold or hot water supply failure

To Specify

New state of the art Galvin Specialised CliniMix® Inwall Thermostatic Progressive Shower Mixer with GalvinCare® Handle Warm and Cold for shower applications.

Specifically designed for mental health and health care facilities featuring an easy to operate on/off temperature control and option to be set to a thermostatically controlled temperature of 48°C maximum.

Suitable for high and low pressure systems, reliable CliniMix® Thermostatic Progressive Shower Mixer is water conserving and cost-effective.

Code:

WM-TMVPMSCS - CliniMix® Inwall Thermostatic Progressive Shower Mixer with GalvinCare® Handle (Warm & Cold)



A family
owned
Australian
business



Performance Standards & Approvals

- AS 4032.4 – WaterMark



WaterMark
AS 4032.4 WMKA 21989
SAI Global

Typical Dimensions

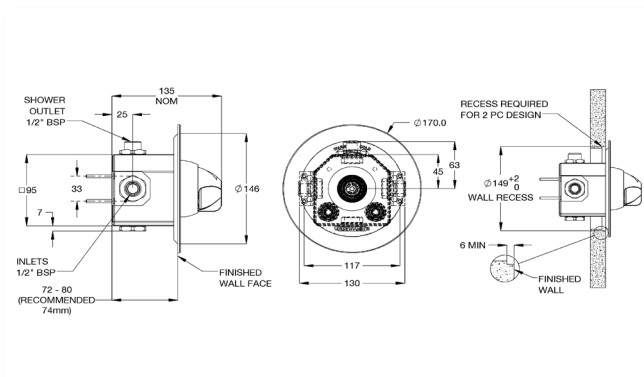

Technical Information

- Inlet: 1/2" BSP - Male
- Outlet: 1/2" BSP - Male
- Headwork: Thermostatic Mixing Valve
- Working Pressure Range (kPa): 20 Min - 500 Max
- Working Temperature Range (°C): 5 Min - 85 Max
- Minimum Temp. Differential (Between Supply and Outlet Temperature) (°C): 10
- Adjustable Temperature Range (°C): 35 Min - 48 Max
- Permitted Supply Pressure Variation: 10:1
- Factory Set Thermostatic Temperature (°C): 41
- Minimum Flow Rate for Stable Outlet Temp. (LPM): 6
- Maximum Flow Rate (LPM): 18 @ 300kPa
- Construction: DZR Brass
- Finish: Chrome

Maintenance & Cleaning

Galvin Specialised products should be cleaned with a soft damp cloth using only mild liquid detergent or soap and water. Do not use cleaning agents containing a corrosive acid, scouring agent or solvents. Do not use cream cleaners, as they are abrasive. Use of unsuitable cleaning agents may damage the surface. Any damage caused in this way will not be covered by warranty.

Regular maintenance should be carried out in accordance with the installation and troubleshooting guides provided with the product, relevant Australian Standards, local authorities and state codes.

Warranty

Galvin Engineering products are covered under our Manufacturer's Warranty at www.galvinengineering.com.au. Galvin Engineering products must be installed in accordance with the installation instructions and in accordance with AS3500 and the PCA, relevant Australian Standards and local authorities applicable to product being installed. Water and electrical supply conditions must also comply to the applicable national and/or state standards, failing to comply with these provisions may void the product warranty and affect performance of the product.

In the absence of a legal or industry definition of anti-ligature or ligature resistant products, when we use these terms, we are referring to products that are designed and manufactured with the intention of reducing the risk of ligature attachment to the product(s). Galvin Engineering Pty Ltd will always endeavour to design and test our anti-ligature product(s) to reduce the risk of product ligature attachment that may result in serious injury or death.

Whilst all reasonable measures are taken at the time of design, the anti-ligature design of the products are not intended to and will not:

- Replace protective measures that need to be taken in the specific circumstances of usage;
- Substitute the need for supervision of those who may be at risk;
- Protect and or prevent those at risk against any self-harm instances that may occur when installed; and
- Protect and or prevent injury when the risks were unknown to us at the time of the design of the product(s).

Galvin Engineering Pty Ltd does not offer and does not represent or warrant that any product(s) for sale that are ligature-free.

Therefore, Galvin Engineering will not be liable for any claims, loss, or damages arising from ligature attachment on our products. It is the purchaser's responsibility to ensure that products purchased and installed are suitable for the environments in which they are installed, and suitable supervision and protective measures are in place to protect those at risk.

Whilst all reasonable care has been taken in compiling the information in this document, the designs, dimensions and products shown are indicative only and should not be relied upon without our prior approval. Due to our policy of continuous development, we reserve the right to alter any details of specifications or products without notice. All information, drawings, technical specifications and product designs remains the property of Galvin Engineering Pty Ltd.

Within Australia: **1300 514 074** Outside Australia: P: +61 (0)8 9338 2344

F: +61 (0)8 9338 2340

sales@galvinengineering.com.au

www.galvinengineering.com.au

ABN: 78 008 719 382

A business unit of

GalvinEngineering
the mark of reliability



PERTH | SYDNEY | MELBOURNE | BRISBANE | ADELAIDE | UNITED STATES OF AMERICA | UNITED KINGDOM | NEW ZEALAND