

Product Installation Guidelines & Scope of Use

Version 1.1, 28 August 2025, Page 1 of 4
Document No: 001.00.10.35

CliniLever® CP-BS Lead Safe™ Hospital Hob Swivel Outlets

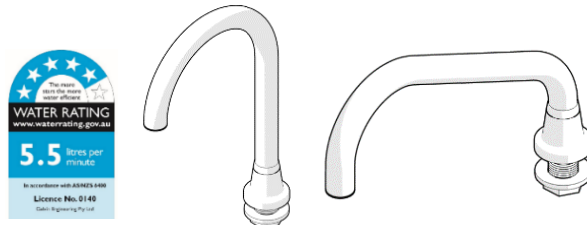

PRODUCT CODES	DESCRIPTION
102.40.92.00	CliniLever® CP-BS Lead Safe™ Hospital G/N Swivel Hob Spout 5/8, 110Long x 90 High Laminar
102.41.92.00	CliniLever® CP-BS Lead Safe™ Hospital G/N Swivel Hob Spout 5/8, 150Long x 160 High Laminar
102.42.92.00	CliniLever® CP-BS Lead Safe™ Hospital G/Neck 5/8 Hob Swivel Outlet 200 Reach x 140 High Laminar
102.43.92.00	CliniLever® CP-BS Lead Safe™ Hospital Upswept 5/8 Hob Swivel Outlet 200 Reach x 80 High Laminar
102.44.92.00	CliniLever® CP-BS Lead Safe™ Hospital Upswept 5/8 Hob Swivel Outlet 240 Reach x 80 High Laminar

SPECIFICATIONS

- The CliniLever® product range is primarily used for hand washing applications in medical facilities, hospitals, aged care facilities, schools and in-home care.
- CliniLever® products provide state of the art features to comply with the latest healthcare guidelines.
- Robust construction for long life.
- Low maintenance.
- Laminar flow.
- Finished in bright chrome plate for easy cleaning and durability.
- Lead Safe™ brass construction.*

IMPORTANT: All CliniLever® healthcare taps are tested in accordance with AS 3718 and leave our premises in good working order.

*Our Lead Safe™ product range is compliant with the Lead Free Requirements of the NCC 2022 Vol. Three, Clause A5G4(2) and NSF/ANSI 372.

**Any flow controller incorporated in the outlet to be tightened to prevent removal by hand. As Per AS3718.

WARNINGS: Special attentions to be paid on notes, photos, images, or drawings of assembly steps marked with the warning symbol.



TECHNICAL DATA

Inlet	G 5/8" – Male	
Outlet	Laminar Flow Aerator	
Working Pressure Range (kPa)	Min	50
	Max	500
Working Temperature Range (°C)	Min	5
	Max	65
Nominal Flow Rate (LPM)	5.12	
Finish	Chrome	

NOTE: Galvin Engineering continually strives to improve their products. Specifications may change without notice.

DIMENSIONS

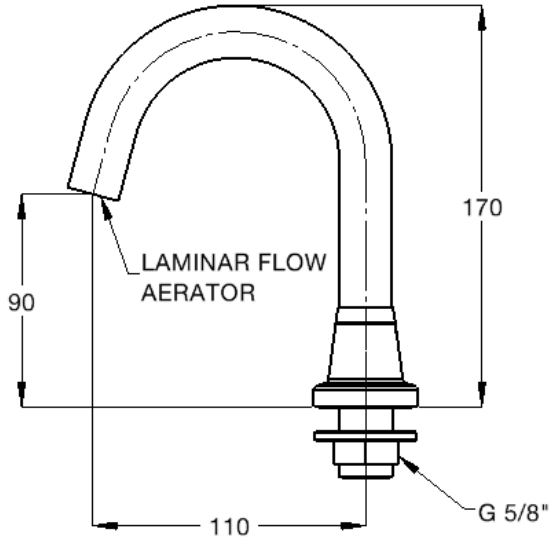

102.40.92.00

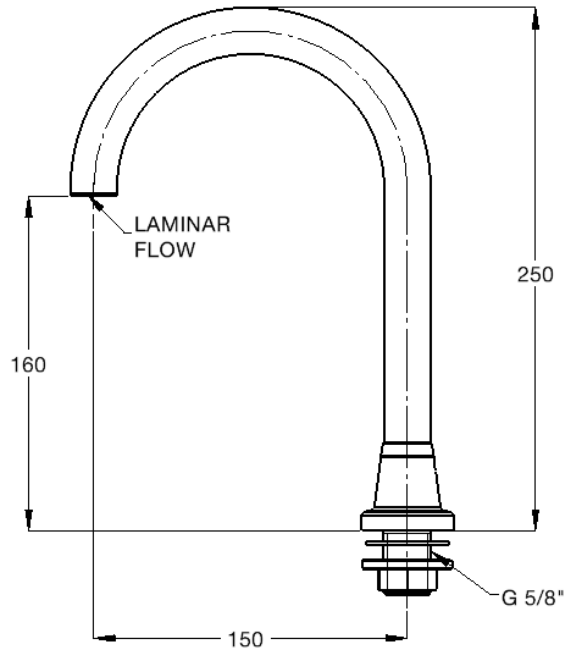

102.41.92.00

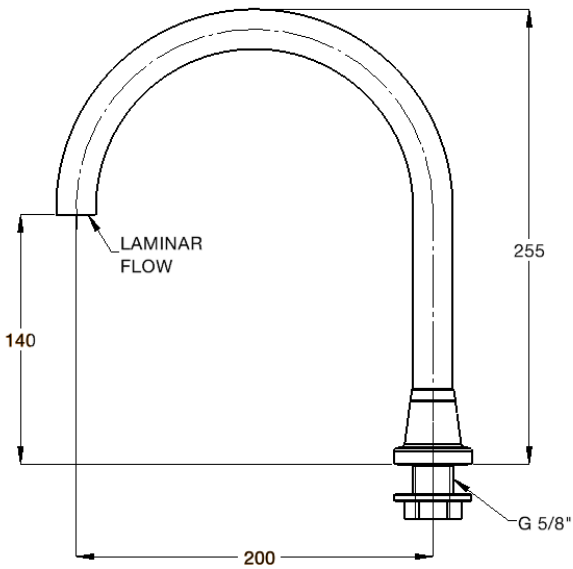

102.42.92.00

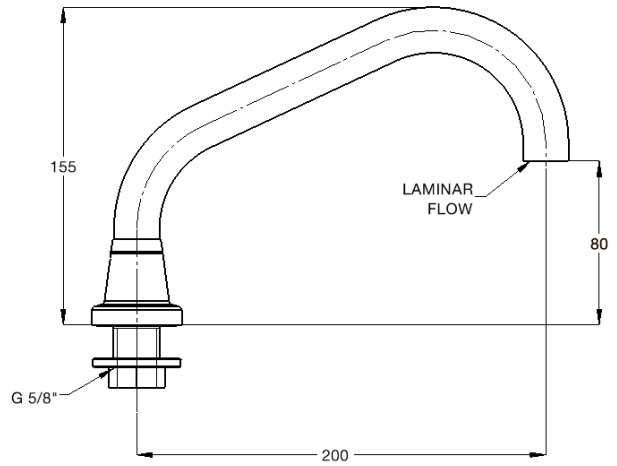

102.43.92.00

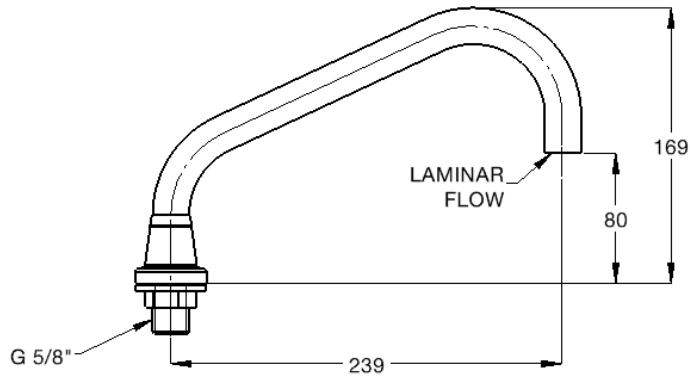

102.44.92.00

INSTALLATION

INSTALLATION COMPLIANCE: Galvin Engineering products must be installed in accordance with these installation instructions and in accordance with AS/NZS 3500, the PCA and your local regulatory requirements. Water and/or electrical supply conditions must also comply to the applicable national and/or state standards. Failing to comply with these provisions shall void the product warranty and may affect the performance of the product.

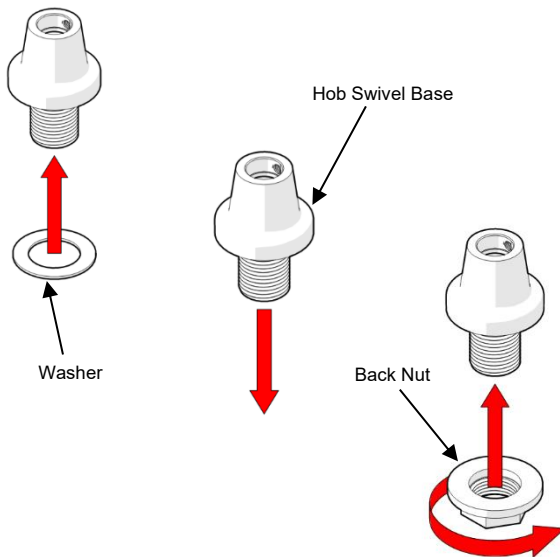

1. Fit Base

- Fit the hob swivel base into the bench. Ensure that the hole for the grub screw is located at the back.
- Ensure the sealing washer is placed underneath the base body.
- Secure the base underneath with supplied flanged backnut

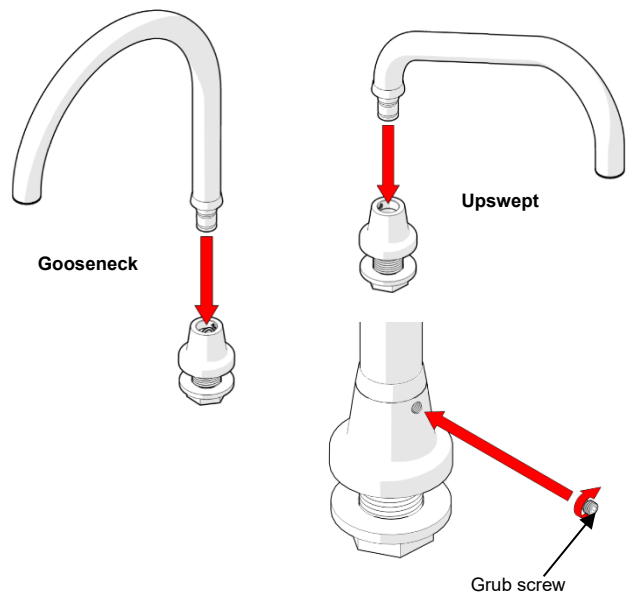

2. Secure Spout

- Insert the spout on the base in the desired position taking into consideration the locking portion for the grub screw.
- Secure position using the grub screw in the hole at the back of the base.

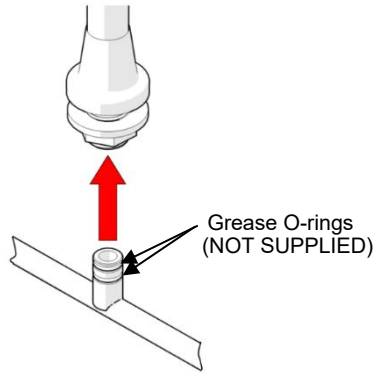

3. Insert to Breach

- Grease o-rings (not supplied) of the current breach piece (not supplied) before inserting to the spout.
- Carefully insert the copper breach outlet into the spout, to avoid damage to the tee o-rings. After full unit is assembled, test for correct operation.

TROUBLESHOOTING

PROBLEM	CAUSE	RECTIFICATION
Inconsistent flow	Blocked aerator Blocked top assembly	Remove aerator and clean Remove top assembly and clean
Water is not flowing from the tap	Water is turned off	Turn on the water
Continuous flow	Top assembly loose or internally obstructed or damaged	Remove top assembly, clean with water and replace if required

WARRANTY

Galvin Engineering products are covered under our Manufacturer's Warranty. Galvin Engineering products must be installed in accordance with the installation instructions and in accordance with AS/NZS 3500 and NCC Volume Three, relevant Australian Standards and local authorities applicable to product being installed. Water and electrical supply conditions must also comply to the applicable national and/or state standards, failing to comply with these provisions may void the product warranty and affect performance of the product.

Please visit www.galvinengineering.com.au to view the full warranty, our Installation Compliance and Maintenance & Cleaning information as well as any other additional information.