

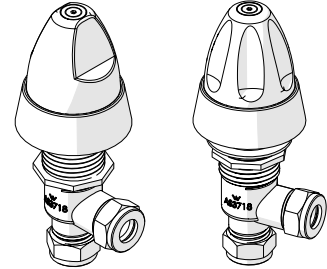

GalvinCare® CP-BS MH Ligature Resistant Basin/Sink Tap

PRODUCT CODES:

- 50101C – Ezy Grip Cold
- 50104C – Multi Grip Cold
- 50107C – Ezy Grip Hot
- 50112C – Multi Grip Hot



SPECIFICATIONS

- Designed for maximum protection against vandalism, GalvinCare® basin/sink assemblies are made from heavy duty components and can be installed from the rear.
- The basin/sink assembly is made of chrome plated brass.
- Quarter turns ceramic disc.
- Machined cold or hot identification button.
- Ligature Resistant design.
- Available with either Ezy-Grip or Multi-Grip handle (as shown above).

IMPORTANT: All GalvinCare® top assemblies are tested in accordance with AS 3718 and leave our premises in good working order.

WARNINGS: Special attentions to be paid on notes, photos, images, or drawings of assembly steps marked with the warning symbol.



TECHNICAL DATA

Inlet	½" CU/BSP	
Outlet	½" CU/BSP	
Headwork	Ceramic	
Working Pressure Range (kPa)	Min	50
	Max	500
Working Temperature Range (°C)	Min	5
	Max	65
Nominal Flow Rate (LPM)	N/A	
Finish	Chrome	

NOTE: Galvin Engineering continually strive to improve their products. Specifications may change without notice.

TOOLS REQUIRED

- Power drill
- Spanner and 2.5mm hex key - to suit M4 Screw
- Thread tape

PRE-INSTALLATION - MOUNTING DETAILS

- If the mounting holes do not already exist, mark out and drill the hole in the bench/trough to suit your requirements.

Note: Before installation, all lines must be flushed. We recommend that a line strainer be installed prior to drinking taps to eliminate any foreign material.

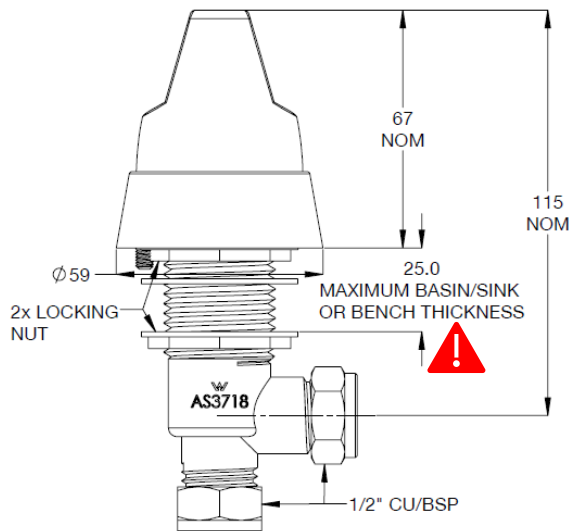
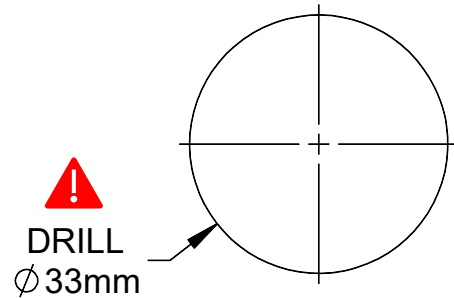

Ezy-Grip Assembly

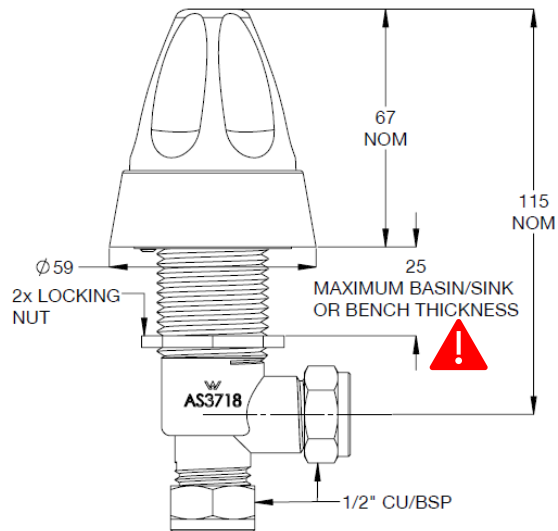

Multi-Grip Assembly

INSTALLATION

INSTALLATION COMPLIANCE: Galvin Engineering products must be installed in accordance with these installation instructions and in accordance with AS/NZS 3500, the PCA and your local regulatory requirements. Water and/or electrical supply conditions must also comply to the applicable national and/or state standards. Failing to comply with these provisions shall void the product warranty and may affect the performance of the product.

IMPORTANT: Whilst our product designs take into account a broad range of installation types and surfaces, it is important that surfaces which fixtures are mounted to are flat and free from defect. This is especially important when installing product ranges that have been designed for correctional and health facilities, where special attention is required to minimise ligature points and areas for concealment of contraband. In addition to ensuring the products are fitted securely and in accordance with the following instructions, consideration shall be given to the use of non-pick mastics such as BASF Sonolastic "Ultra" to ensure a high quality and safe installation.

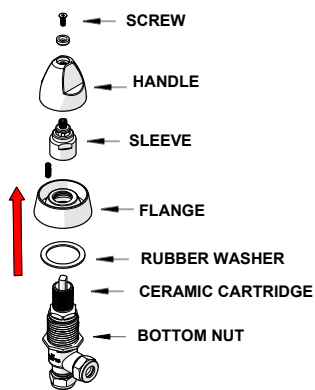

1. Disassembly

- Disassemble components by removing screw first using hex key, leaving bottom nut on the body.
- Do not remove the ceramic cartridge

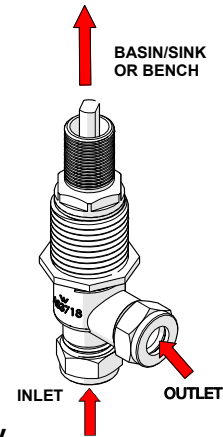

2. Fit basin body

- Insert the basin body assembly up through the pre-cut hole.

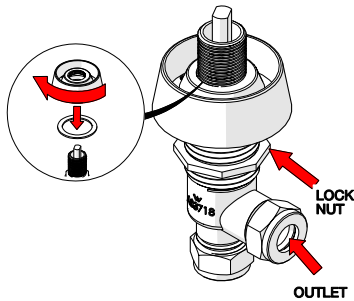

3. Fit dress flange

- Fit onto dress flange and hand tighten.
- Tighten the breach piece sealing.
- Tighten bottom nut

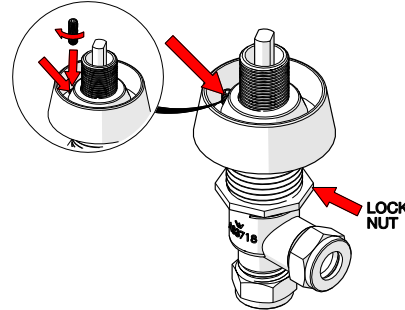

4. Fit dress flange with Anti-Rotation pin

- If the anti-rotation option is required, fit dress flange onto body and mark the basin/sink, remove the flange and drill 10mm deep 6.0mm hole.
- Replace the flange and screw in the grub screw to lock.

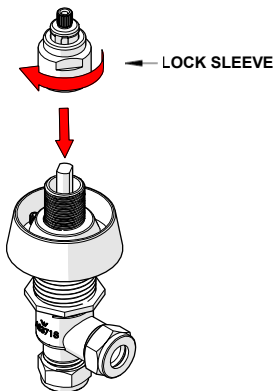

5. Fit lock sleeve

- Fit lock sleeve and tighten.

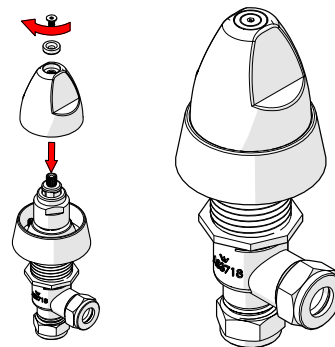

6. Assemble handle and test

- Fit handle with tamper proof screw, ensure the correct water temperature identification button is in the handle.
- Screw must be tightened before the unit is tested.
- Check the operation of the unit and inspect for any leaks.

TROUBLESHOOTING

PROBLEM	CAUSE	RECTIFICATION
Taps are dripping water	Ceramic cartridge is worn or damaged	Remove and inspect the cartridge, remove debris and /or replace cartridge if damaged
	Tap seat is damaged	Refurbish tap seat using a reseating tool
Water is not flowing from tap	Water is turned off	Turn on water

WARRANTY

Galvin Engineering products are covered under our Manufacturer's Warranty. Galvin Engineering products must be installed in accordance with the installation instructions and in accordance with AS/NZS 3500 and NCC Volume Three, relevant Australian Standards and local authorities applicable to product being installed. Water and electrical supply conditions must also comply to the applicable national and/or state standards, failing to comply with these provisions may void the product warranty and affect performance of the product.

Please visit www.galvinengineering.com.au to view the full warranty, our Installation Compliance and Maintenance & Cleaning information as well as any other additional information.

DEFINITIONS AND DISCLAIMER

Galvin Engineering manufactures a range of products marked as Ligature Resistant or Vandal Resistant. Please visit www.galvinengineering.com.au to read the definition of these terms and the disclaimer that applies to these products.