

Product Installation Guidelines & Scope of Use

GalvinCare® CP-BS Lead Safe™ Ligature Resistant Concealed Timeflow Push Button Valve - 15 Sec

PRODUCT CODE:

- 121.05.25.00

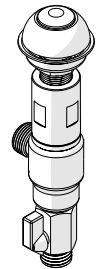

SPECIFICATIONS

- The GalvinCare® Time flow Push Button Valve is used in high risk and secure environments, sporting facilities, schools and public area applications
- Time is affected by temperature, flow rate and pressure, and is based on set at 500kPa, 4LPM @ 22°C.
- Once activated, this timed flow product will allow water to flow for approximately 15 seconds.
- Designed for easy bench installation (maximum thickness 10mm)
- Lead Safe™ brass construction. *

Note: This is a single temperature product, so if warm water is required this needs to be premixed prior to reaching the valve. This can be done by using a CliniMix® Thermostatic Mixing Valve.

IMPORTANT: All GalvinCare® taps are tested in accordance with AS 3718 and leave our premises in good working order.

*Our Lead Safe™ product range is compliant with the Lead-Free Requirements of the NCC 2022 Vol. Three, Clause A5G4(2) and NSF/ANSI 372.

** Any flow controller incorporated in the outlet to be tightened to prevent removal by hand. As Per AS3718.

WARNINGS: Special attention to be paid on notes, photos, images, or drawings of assembly steps marked with the warning symbol.



TECHNICAL DATA

Inlet	R ½" – Male	
Outlet	G ½" – Male	
Headwork	Time flow cartridge	
Working Pressure Range (kPa)	Min	100
	Max	500
Working Temperature Range (°C)	Min	5
	Max	65
Nominal Flow Rate (LPM)	2.52	
Finish	Chrome	

NOTE: Galvin Engineering continually strive to improve their products. Specifications may change without notice.

TOOLS REQUIRED

- Power drill
- Spanner or adjustable crescent

PRE-INSTALLATION

MOUNTING DETAILS

- If the mounting holes do not already exist, mark out and drill the holes in the bench/trough, as shown in rough-in dimensions.
- Please note the maximum thickness of the bench/trough is 10mm.

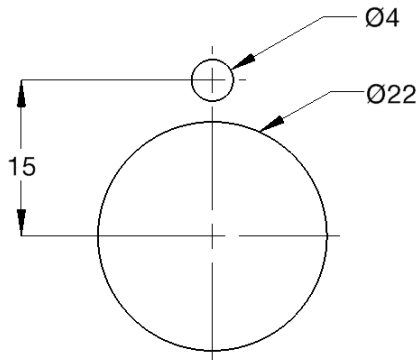

ROUGH-IN DIMENSIONS

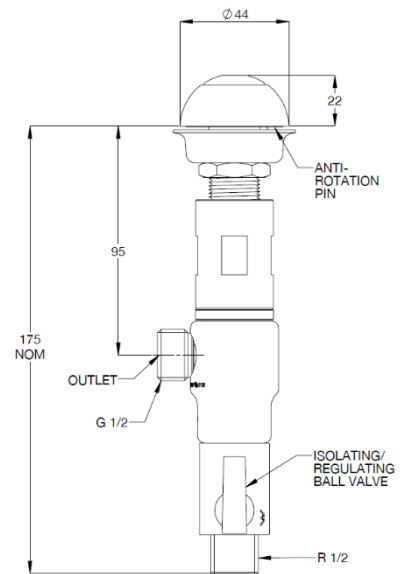

INSTALLATION

INSTALLATION COMPLIANCE: Galvin Engineering products must be installed in accordance with these installation instructions and in accordance with AS/NZS 3500, the PCA and your local regulatory requirements. Water and/or electrical supply conditions must also comply to the applicable national and/or state standards. Failing to comply with these provisions shall void the product warranty and may affect the performance of the product.

IMPORTANT: Whilst our product designs take into account a broad range of installation types and surfaces, it is important that surfaces which fixtures are mounted to are flat and free from defect. This is especially important when installing product ranges that have been designed for correctional and health facilities, where special attention is required to minimise ligature points and areas for concealment of contraband. In addition to ensuring the products are fitted securely and in accordance with the following instructions, consideration shall be given to the use of non-pick mastics such as BASF Sonolastic "Ultra" to ensure a high quality and safe installation.

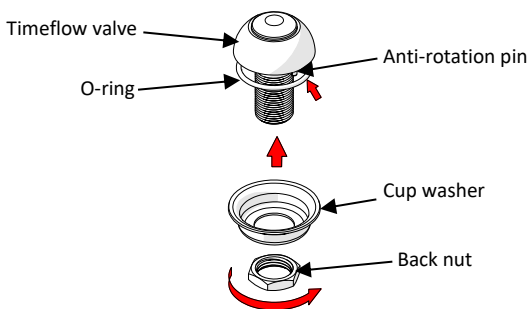

1. Fit push button

- Fit the push button into the bench.
- Ensure the sealing o-ring is placed underneath the push button and the anti-rotation pin locates properly.
- Secure underneath with the supplied cup washer and back nut.

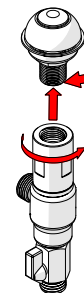

2. Assemble valve body

- Assemble the valve body to the push button.
- Ensure to apply thread tape for sealing. Take care not to over-tighten.

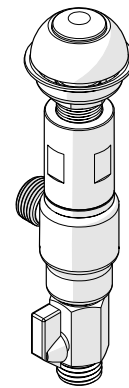
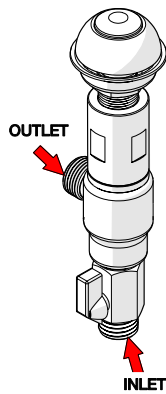

3. Fit inlet and outlet connections

- Fit outlet connection.
- Connect water supply to isolation valve inlet

4. Testing

- Turn mains supply on and push button to ensure that there is flow from outlet.
- Inspect the tap and check for any leaks.
- Adjust flow with isolation valve, so required flow is achieved

TROUBLESHOOTING

PROBLEM	CAUSE	RECTIFICATION
Inconsistent flow	Blocked flow restrictor	Remove isolation valve, remove flow restrictor & clean with water
	Dirt in the top assembly cartridge	Remove cartridge, clean with water and re-grease spindle if required.
Continuous flow	Top assembly cartridge loose, internally obstructed or damaged.	Remove cartridge, clean with water and re-grease spindle if required.
Water is not flowing from tap	Supply not on	Turn water supply on
	Blocked flow restrictor	Remove flow restrictor from tap and remove debris. Install an in-line strainer to stop further blockages.
	Isolation valve is closed	Open isolation valve
Rate of flow inadequate	Isolation valve is positioned wrong	Adjust isolation valve until desired flow is achieved
Button hard to press	The mains pressure may be too great	Reduce to below 500kPa (70PSI), re-grease spindle if required

WARRANTY

Galvin Engineering products are covered under our Manufacturer's Warranty. Galvin Engineering products must be installed in accordance with the installation instructions and in accordance with AS/NZS 3500 and NCC Volume Three, relevant Australian Standards and local authorities applicable to product being installed. Water and electrical supply conditions must also comply to the applicable national and/or state standards, failing to comply with these provisions may void the product warranty and affect performance of the product.

Please visit www.galvinengineering.com.au to view the full warranty, our Installation Compliance and Maintenance & Cleaning information as well as any other additional information.

DEFINITIONS AND DISCLAIMER

Galvin Engineering manufactures a range of products marked as Ligature Resistant or Vandal Resistant. Please visit www.galvinengineering.com.au to read the definition of these terms and the disclaimer that applies to these products.