

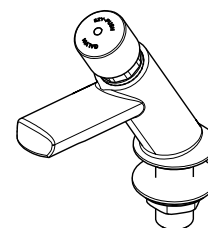

# Ezy-Push® CP-BS Timeflow Push Button Pillar Tap – 6 Sec

## PRODUCT CODES:

- 368696



### SPECIFICATIONS

- Time flow taps are designed to operate at full mains pressure.
- The valve has a unique self-closing operation.
- The taps are made of chrome plated brass.
- Clean hygienic design.
- Water saving and vandal resistant.
- Low maintenance and easy to operate.
- Supplied with hot (red), warm (yellow) and cold (blue) buttons depending on the requirement.
- Smooth round designs to facilitate easy clean and help reduce dirt and bacteria growth.

*Note: Time is based on 500kPa, @ 22 degrees Celsius. Time will vary plus or minus 30% based on water temperatures, pressures, flow rates and water quality.*

**IMPORTANT:** All Ezy-Push® Time Flow Pillar Taps are tested in accordance with AS/NZS 3718 and leave our premises in good working order. Time may vary due to changes in temperature, pressure, flow rate and water quantity.

### TECHNICAL DATA

Inlet	½" BSP - Male	
Outlet	Flow Straightener	
Headwork	Time Flow Cartridge	
Working Pressure Range (kPa)	Min	100
	Max	500
Maximum Working Temperature (°C)	Min	5
	Max	65
Nominal Flow Rate (LPM)	4.9	
Construction	Brass	
Finish	Chrome	

**NOTE:** Galvin Engineering continually strive to improve their products. Specifications may change without notice.

### TOOLS REQUIRED

- Power drill
- Spanner or adjustable crescent
- Screw driver



## PRE-INSTALLATION

### MOUNTING DETAILS – HOLE CENTRES

- If the mounting holes do not already exist, mark out and drill the holes in the bench/trough, as shown in rough-in dimensions.

**Note:** Before installation, all lines must be flushed. We recommend that a line strainer be installed prior to Ezy-Push Time Flow Pillar taps to eliminate any foreign material.

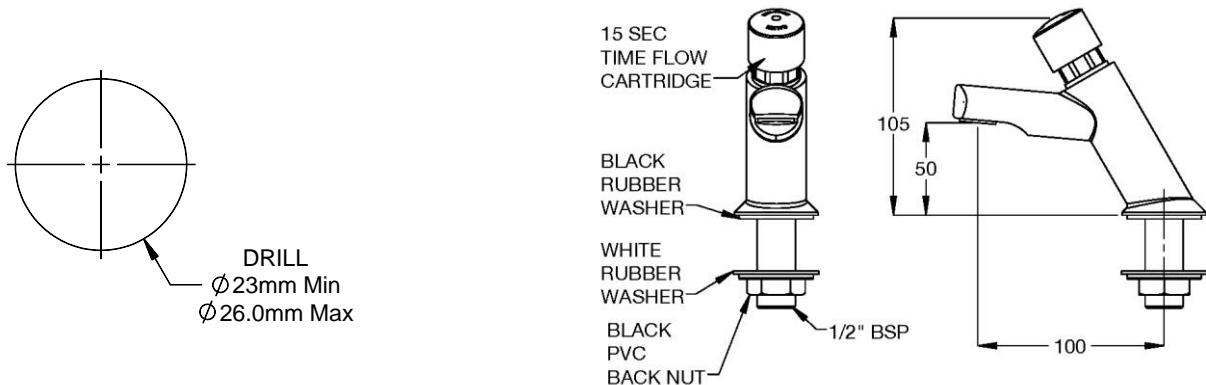

## INSTALLATION

**IMPORTANT:** Galvin Engineering products must be installed in accordance with these installation instructions and in accordance with AS/NZS 3500, the PCA and your local regulatory requirements. Water and/or electrical supply conditions must also comply to the applicable national and/or state standards. Failing to comply with these provisions shall void the product warranty and may affect the performance of the product.

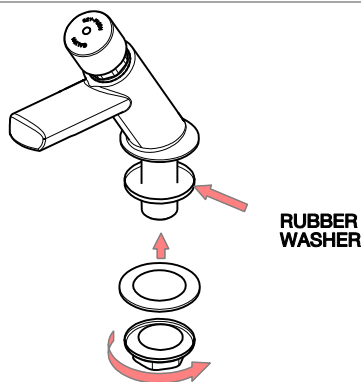

### 1. Fit tap assembly

- Fit the tap body into the bench. Ensuring one of the sealing rubber washers is placed underneath the tap body.
- Secure underneath with the other sealing rubber washer and back nut.
- Time flow taps are fitted with flow restrictors.
- When applying thread tape or sealant to the inlet, ensure the opening is not obscured. Failure to do so may restrict or block the flow restrictor, affecting the flow of water.

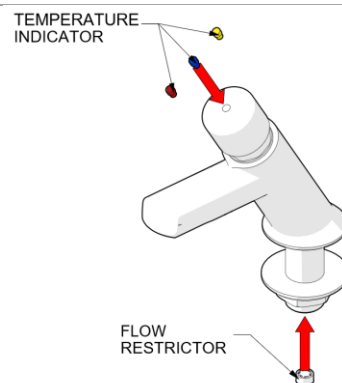

### 2. Replacing flow restrictor (if required) and fitting water temperature indicator

- Major restrictions to the supply pressure (eg. refrigeration units) may affect the water stream and the flow restrictor may need replacing with a restrictor of greater capacity to increase the flow. However, using a different flow restrictor will void the 6 star rating.
- Never operate without a flow restrictor, as Ezy-Push® Time flow taps will deliver full mains pressure with unrestricted flow.
- Fit the appropriate water temperature indicators (Cold, Hot or Warm).

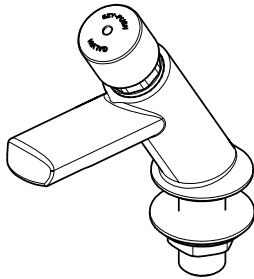

### 3. Testing

- Once fitted, connect the water lines & turn on water.
- Check for leaks and correct operation.

## TROUBLESHOOTING

PROBLEM	CAUSE	RECTIFICATION
Water is not flowing or inconsistent flow.	Blocked flow restrictor / dirt in the cartridge / water supply not on.	Remove flow regulator from outlet and remove debris. Install an inline strainer to stop further blockages. Ensure water supply is turned on.
Continous flow of water.	Top assembly cartridge loose or internally obstructed or damaged.	Remove cartridge, clean with water and re-grease spindle if required.
Rate of flow inadequate.	The flow restrictor may not be satisfactory due to inadequate supply pressure.	Remove flow restrictor and replace with a flow restrictor of different capacity to suit (available from Galvin Engineering).
Button hard to activate.	Mains pressure may be too high.	Reduce mains pressure to below 500kPa.
Water shuts off upon release the button.	Small spring at the bottom of the cartridge piston dislodged.	Relocate spring, regrease spindle if required.



## WARRANTY

The warranty set forth herein is given expressly and is the only warranty given by the Galvin Engineering Pty Ltd. With respect to the product, Galvin Engineering Pty Ltd makes no other warranties, express or implied. Galvin Engineering Pty. Ltd. hereby specifically disclaims all other warranties, express or implied, including but not limited to the implied warranties of merchantability and fitness for a particular purpose.

Galvin Engineering Pty Ltd products are covered under our manufacturer's warranty available for download from [www.galvinengineering.com.au](http://www.galvinengineering.com.au) Galvin Engineering Pty Ltd expressly warrants that the product is free from operational defects in workmanship and materials for the warranty period as shown on the schedule in the manufacturer's warranty. During the warranty period, Galvin Engineering will replace or repair any defective products manufactured by Galvin Engineering without charge, so long as the terms of the Manufacturer's warranty are complied with.

The remedy described in the first paragraph of this warranty shall constitute the sole and exclusive remedy for breach of warranty, and Galvin Engineering Pty Ltd shall not be responsible for any incidental, special or consequential damages, including without limitation, lost profits or the cost of repairing or replacing other property which is damaged if this product does not work properly, other costs resulting from labour charges, delays, vandalism, negligence, fouling caused by foreign material, damage from adverse water conditions, chemical, electrical or any other circumstances over which Galvin Engineering has no control. This warranty shall be invalidated by any abuse, misuse, misapplication, improper installation or improper maintenance or alteration of the product.