

CliniLever® Healthcare Tapware

PRODUCT CODES:

- TC50SC1C - TC50FC1C
- TC50SJ1C - TC50FJ1C



TC50F - SERIES TC50S-SERIES

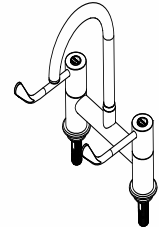

SPECIFICATIONS

- The CliniLever® product range is primarily used for hand washing applications in medical facilities, hospitals, aged care facilities, schools and in-home care.
- CliniLever® products provide state of the art features to comply with the latest healthcare guidelines.
- The dual levers are easy to access and operate which simplifies hand washing.
- All CliniLever® products are laminar flow (not aerated).
- Our highly sought after lever handle design can be operated with elbows or wrists to avoid hand contact.
- The main body is made of solid dezincification resistant (DR) brass rod, with a DR brass gooseneck outlet.
- Quick action SBA's include brass jumper valve / ceramic cartridge components, with red and blue indicator buttons on 80mm or 150mm lever action handles.

IMPORTANT: All CliniLever® healthcare taps are tested in accordance with AS/NZS 3718 and leave our premises in good working order.

TECHNICAL DATA

Inlet	1/2" BSP – Male		
Outlet	Laminar Flow		
Headwork	Jumper Valve / Ceramic Disc		
Working Pressure Range (kPa)	Min	50	
	Max	500	
Working Temperature Range (°C)	Jumper Valve/Ceramic	Min	5
	Jumper Valve	Max	65
	Ceramic	Max	65
Nominal Flow Rate (LPM)	TC50FC1C, TC50FJ1C		6.74
	TC50SC1C, TC50SJ1C		6.3
Finish	Chrome		

NOTE: Galvin Engineering continually strive to improve their products. Specifications may change without notice.

TOOLS REQUIRED

- Power drill, spanner
- Thread tape

Product Installation Guideline

PRE-INSTALLATION - MOUNTING DETAILS

- If the mounting holes do not already exist, mark out and drill the holes in the bench/trough to suit your requirements. The hole centres for the handles must be 205mm

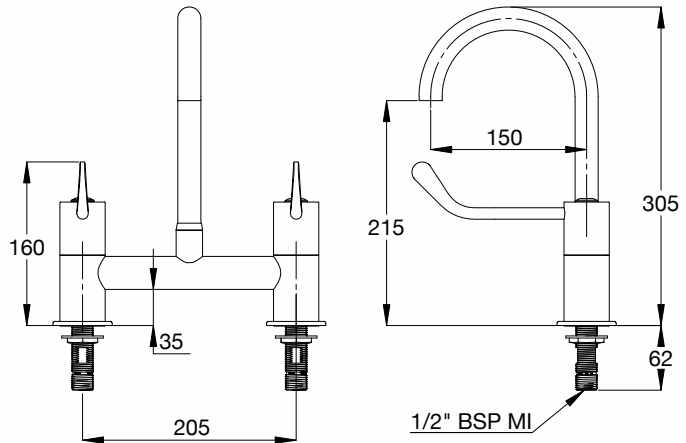
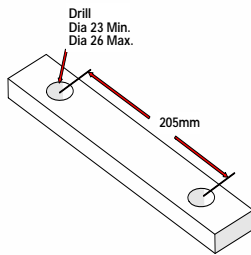

INSTALLATION

IMPORTANT: Galvin Engineering products must be installed in accordance with these installation instructions and in accordance with AS/NZS 3500, the PCA and your local regulatory requirements. Water and/or electrical supply conditions must also comply to the applicable national and/or state standards. Failing to comply with these provisions shall void the product warranty and may affect the performance of the product.

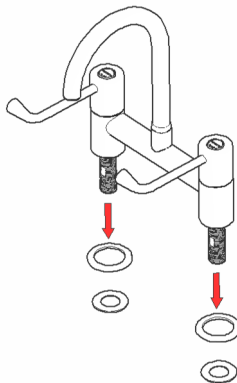

1. Fit hob flange

- Place the Clinilever® flanges over the holes in the bench.
- Ensure sealing washers are placed underneath the flanges.

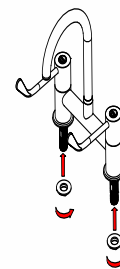

2. Fit Clinilever® unit

- Fit Clinilever® unit into the bench and ensure the body locates into the flanges.
- Secure underneath with supplied flanged back nuts.

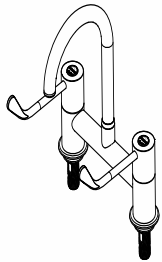

3. Testing

- Once secured, connect the hot and cold water.
- Open the lever handles and ensure there is flow from both hot and cold inlets. Inspect the tap and check for any leaks.

TROUBLESHOOTING

PROBLEM	CAUSE	RECTIFICATION
Taps are dripping water	Jumper valves are worn or damaged	Replace jumper valve
	Ceramic discs are worn or damaged	Remove and inspect SBA. Remove debris and/or replace SBA if damaged.
	Tap seat is damaged	Refurbish tap seat using a reseating tool.
Water is leaking from spindle	O-ring on jumper valve spindle is damaged or worn	Replace o-ring
Water is not flowing from tap	Water is turned off	Turn water on
	Aerator or flow regulator is blocked by debris	Remove aerator and/or flow regulator from tap and remove debris. Install an inline strainer.
Spindle is difficult to turn (jumper valve)	Build up of scale on spindle, spindle worn or o-ring has been damaged	Remove jumper valve, clean and regrease. Replace o-ring. Complete SBA may need to be replaced.
Handle is loose	Screw has come loose	Tighten handle screw
Flange does not screw down onto basin/sink surface	Tap bodies are set too far out	Re-position tap bodies and breach piece

Product Installation Guideline

SERVICE AND MAINTENANCE

JUMPER VALVE TAPWARE	CERAMIC CARTRIDGE TAPWARE
<ol style="list-style-type: none">1. Turn off the water supply and turn on the tap handle to drain water from the bodies.2. Remove the temperature indicator from the handle.3. Remove the handle from the tap.4. Unscrew the top assembly from the body.5. Check the o-ring on the spindle and the jumper valve for wear and damage. Replace if required.6. Clean the spindle and body of debris.7. Place a new o-ring (if required) onto the spindle and re-grease with potable water approved grease.8. Re-assemble top assembly. Follow the product installation guidelines for the relevant product to re-assembly method.	<ol style="list-style-type: none">1. Turn off the water supply and turn on the tap handle to drain water from the bodies.2. Remove the temperature indicator from the handle.3. Remove the handle from the tap.4. Unscrew the ceramic head part from the body.5. Check the o-ring on the ceramic head part for wear and damage. Replace if required.6. Clean the head part and the body of any debris.7. Replace the cartridge and hand tighten back into the body.8. Follow the product installation guidelines for the relevant product to re-assemble.

WARRANTY

The warranty set forth herein is given expressly and is the only warranty given by the Galvin Engineering Pty Ltd. With respect to the product, Galvin Engineering Pty Ltd makes no other warranties, express or implied. Galvin Engineering Pty. Ltd. hereby specifically disclaims all other warranties, express or implied, including but not limited to the implied warranties of merchantability and fitness for a particular purpose.

Galvin Engineering Pty Ltd products are covered under our manufacturer's warranty available for download from www.galvinengineering.com.au Galvin Engineering Pty Ltd expressly warrants that the product is free from operational defects in workmanship and materials for the warranty period as shown on the schedule in the manufacturer's warranty. During the warranty period, Galvin Engineering will replace or repair any defective products manufactured by Galvin Engineering without charge, so long as the terms of the Manufacturer's warranty are complied with.

The remedy described in the first paragraph of this warranty shall constitute the sole and exclusive remedy for breach of warranty, and Galvin Engineering Pty Ltd shall not be responsible for any incidental, special or consequential damages, including without limitation, lost profits or the cost of repairing or replacing other property which is damaged if this product does not work properly, other costs resulting from labour charges, delays, vandalism, negligence, fouling caused by foreign material, damage from adverse water conditions, chemical, electrical or any other circumstances over which Galvin Engineering has no control. This warranty shall be invalidated by any abuse, misuse, misapplication, improper installation or improper maintenance or alteration of the product.