

## GalvinCare® Ligature Resistant Electronic Ducted Dual Temperature Basin Assembly with Controller

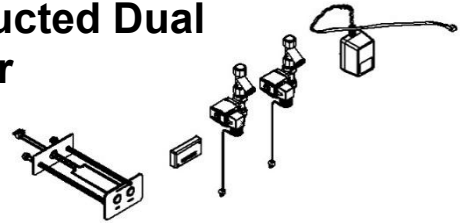

**PRODUCT CODE:**  
- TZ-FLOWTBAS2DT

### SPECIFICATIONS

- GalvinCare® dual temperature basin assembly provides the complete ligature and vandal resistant solution. The unique electronic valve assembly provides a precise delivery of water and is specifically designed for High risk and Secure environments.
- 4mm thick exposed stainless steel faceplate to suit back mounted applications and face plate features push activation buttons. Plates have no front penetrations and are fixed from the duct.
- Basin unit comes with stainless steel water hammer resistant 24V AC solenoids.
- GalvinCare® Electronic controller is a 24V AC electronic control system allowing connection of up to 2 button inputs and up to 2 solenoids. Controller is pre-programmed and ready to use. The solenoids will open for a specific time once the appropriate button is pressed. The standard program can be modified to suits individual needs. To modify the operation settings a compatible Android device with Bluetooth is required.

### TECHNICAL DATA

<b>Power Supply</b>	Type		Transformer
	Input		230-240V – 50Hz
	Output		24V AC 0.9AMPS 22VA
	Cable length		3m
<b>Solenoid</b>	Input Voltage		24V – 50Hz - 60Hz
	Power Consumption		8W
	Cable length		5m
	Connection	Inlet	½” BSP - Female
		Outlet	½” BSP - Male
	Pressure Range (kPa)	Min	100
		Max	500
Temperature (°C)	Min	5	
	Max	90	
<b>Sensor</b>	Type		IP68 24V
	Activation		Push Button
	Connections		2 pin connector
	Cable length		5m
<b>Controller</b>	Input Voltage		24V AC
	Program type		Flowmatic
	Connections		2 pin connectors
Finish (user)			Stainless Steel
Nominal Flow Rate (LPM)			N/A

**NOTE:** Galvin Engineering continually strive to improve their products. Specifications may change without notice.

**WARNINGS:** Special attentions to be paid on notes, photos, images, or drawings of assembly steps marked with the warning symbol.



## PRE - INSTALLATION

### **IMPORTANT:**

- *INSTALLATION COMPLIANCE: Galvin Engineering products must be installed in accordance with these installation instructions and in accordance with AS/NZS 3500, the PCA and your local regulatory requirements. Water and/or electrical supply conditions must also comply to the applicable national and/or state standards. Failing to comply with these provisions shall void the product warranty and may affect the performance of the product (Refer supplied installation compliance sheet with the product).*
- Pipe sizing shall comply with AS/NZS 3500.1 and shall be hydraulically calculated.
- Before proceeding with installation first check the solenoid valve supplied is suitable for the site water pressure and conditions. If your water pressure is outside the stated range, please contact Galvin Specialised.
- Ensure all supply lines are flushed thoroughly to remove debris prior to the installation of this product. A line strainer is supplied to protect the solenoid valve from debris.
- We recommended a thermostatic mixing valve is used to provide premixed water to the valve and pressure reduction valve may be required to comply with recommended maximum supply pressure.
- Ensure that access to the push button, solenoid valve and transformer/GPO is available for future maintenance when installing the components. It is recommended that isolating valves be installed upstream to the solenoid valve to allow for servicing. All wiring must be able to be removed when installed into cavities or walls, therefore, it is recommended that a minimum of 25mm conduit be used to house the leads. The unit is supplied with 5 meters of lead on the transformer and a 5 meters lead from the solenoid. Additional lead lengths may be accommodated up to a length of 5m but must be ordered separately.
- Whilst our product designs consider a broad range of installation types and surfaces, it is important that surfaces which fixtures are mounted to are flat and free from defect. This is especially important for our GalvinCare® range where special attention is required to minimise ligature points and areas for concealment of contraband. In addition to ensuring the products are fitted securely and in accordance with the following instructions, consideration shall be given to the use of non-pick mastics such as BASF Sonolastic "Ultra" to ensure a high quality and safe installation.
- Most installation problems are due to damage to the unit during installation or the selection of an inappropriate installation location. Select the location carefully and take care with the installation, consider ease of operation for the end user.

## GENERAL INSTALLATION REQUIREMENTS

- Do not cut the wires or extended the existing leads without using a correct lead extension from Galvin Engineering, as this will void warranty.
- Suitable access to the service of all components must be provided.
- It is recommended that acoustic dampening products or materials be used in facilities where increased levels of sound protection are required. A water hammer arrestor may also be required.
- The number of valves and simultaneous demand must be considered when sizing pipes. If other fixtures are connected to the supply line, calculations of flow rates and pressures must be undertaken to ensure adequate water supply.
- Limit the number of changes of directions in pipe work. This will result in less friction loss, better valve performance and reduce potential water cavitation noise.
- We recommended fitting isolating valves before solenoid for easy servicing.
- Do not apply heat near this product during connecting water line. Heat generated by soldering could damage plastic or electrical parts and seals and will void the warranty.
- For personal installation assistance and spare parts, please call our head office on 1300 514 074 and speak to our customer service staff.

**MOUNTING DETAILS**

**Face plate cut out position**

Locate push button face plate at a suitable distance from the outlet (we recommend 300mm from the centre of the outlet and at a suitable height or to project specification)

Note: The outlet can be either wall mounted or hub mounted (Outlets are not supplied and must be ordered separately).

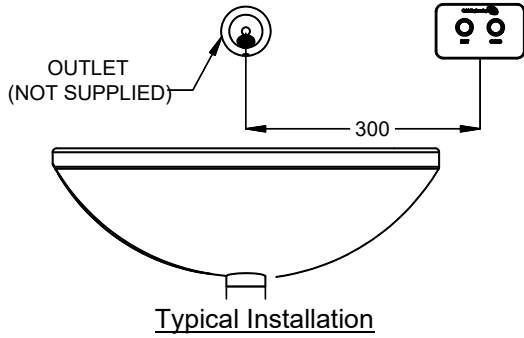

**Cut out details for face plate**

- Faceplate to suit wall thickness between 30mm to 240mm. Ensure the cut out details are as below and the wall thickness does not exceed 240mm.

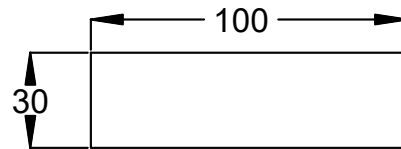

**COMPONENT DIMENSIONS**

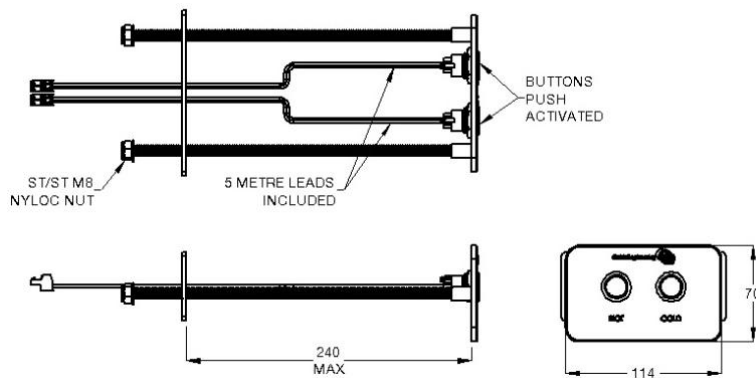

**STAINLESS STEEL FACE PLATE ASSEMBLY**

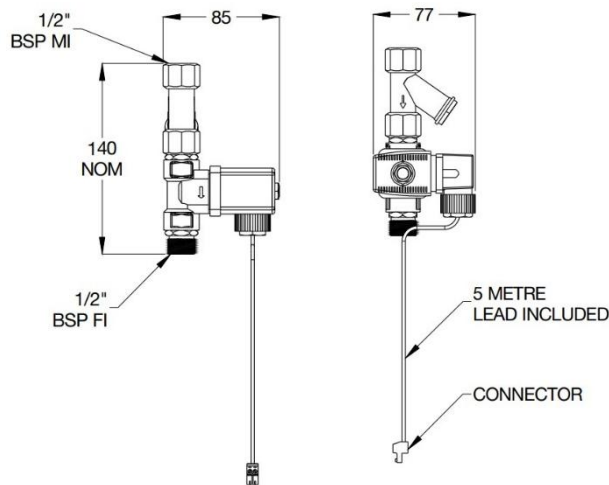

**SOLENOID ASSEMBLY**

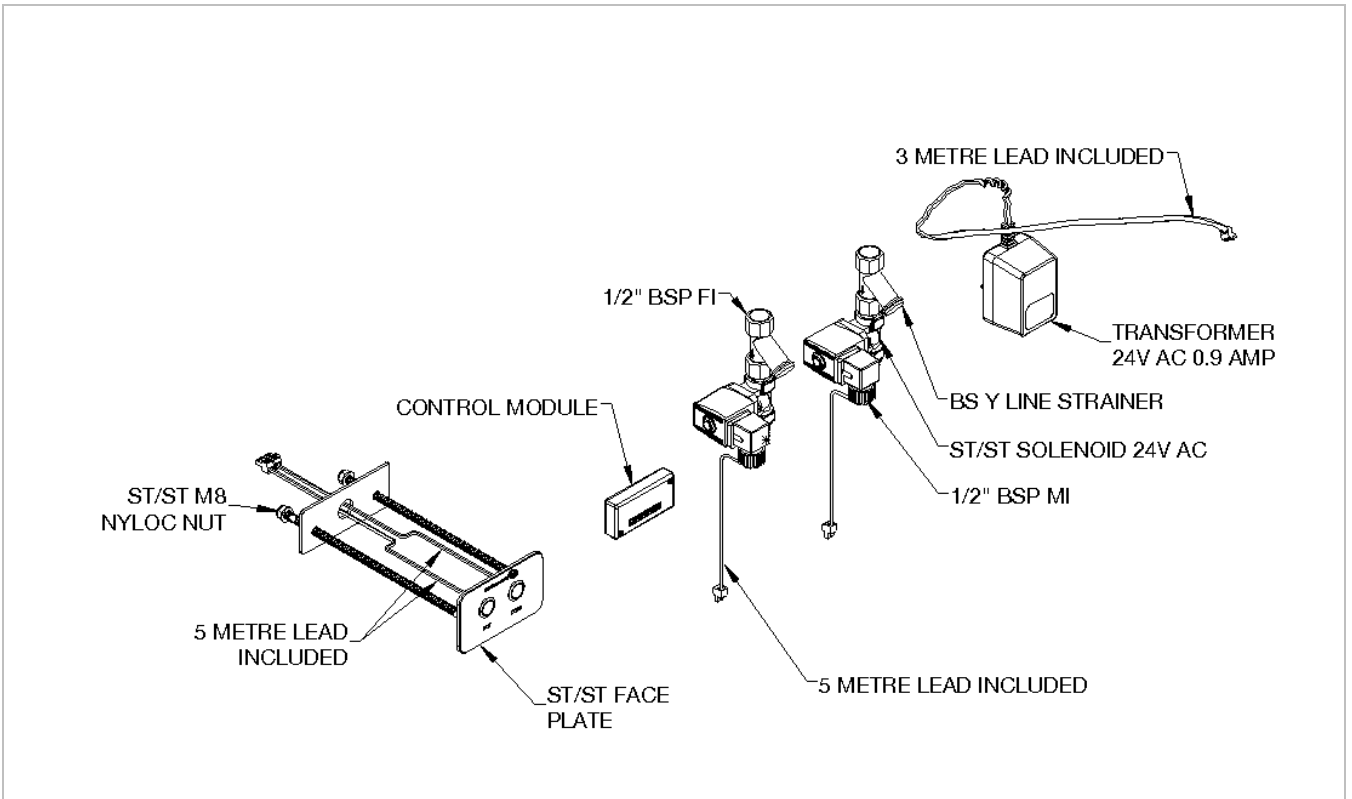

## INSTALLATION

### **⚠ Avoid common installation errors :**

- Incorrect supply pipe size installed.
- Non-compliance to Australian Standards.
- Water pressure not tested before installation
- Lines not flushed before installation.
- No access for service.
- Valve not commissioned properly.

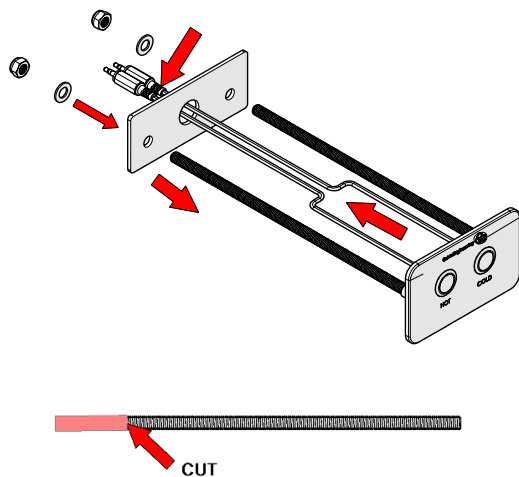

### **1. Mount face plate**

- The stainless steel face plate is always mounted flush to the wall.
- Mount faceplate to the wall using the back plate and nyloc nuts (Do not over tighten max.35 Nm).
- Cut the studs to suit if required.
- Ensure button leads are pushed through the centre hole in back plate before tightening the nyloc nuts and apply a thin bead of silicon on the edge of the wall cut out.
- **If extension leads are required, please contact Galvin Engineering.**

**⚠ Do not force the faceplate to fit onto wall or attempt to disassemble components, as this could result in damage to sensor push button.**

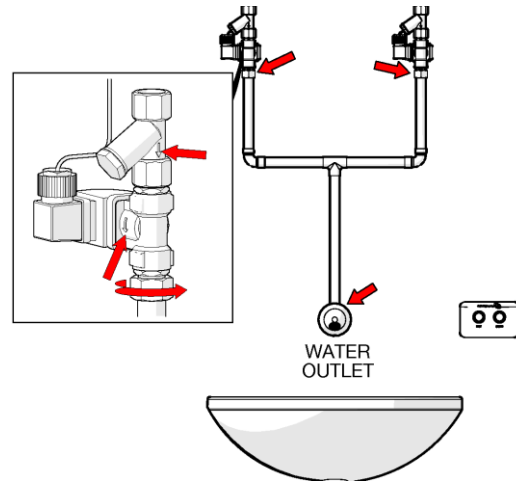

Typical Installation

### **2. Connect solenoid**

- Connect solenoid assemblies to the outlet as shown and in accordance with AS/NZS 3500.
- Ensure that the solenoid is installed in the correct direction (the arrow on the solenoid body must align with the direction of water flow).
- Line strainers are supplied attached to the solenoid valves. Removal of these strainers may void the warranty.

**⚠ Ensure no thread tape, copper swarf, sand or other debris enters and fouls the solenoid valve.**

**⚠ Make sure solenoid valve is orientated such that the electrical wiring is not twisted and connectors are easily accessible.**

**Note:** Refer to solenoid operating instructions manual for installation and service maintenance.

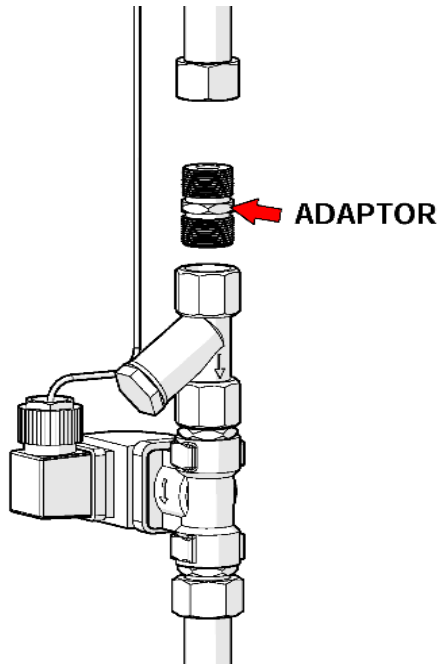

### 3. Connect water

- Connect the water supply to the strainers and turn on water supply. Check for leaks.
- Adaptors supplied by the installer must be in accordance with AS/NZS 3500.

**⚠ Do not apply heat near this product. Heat generated by soldering could damage plastic or electrical parts and seals and will void the warranty.**

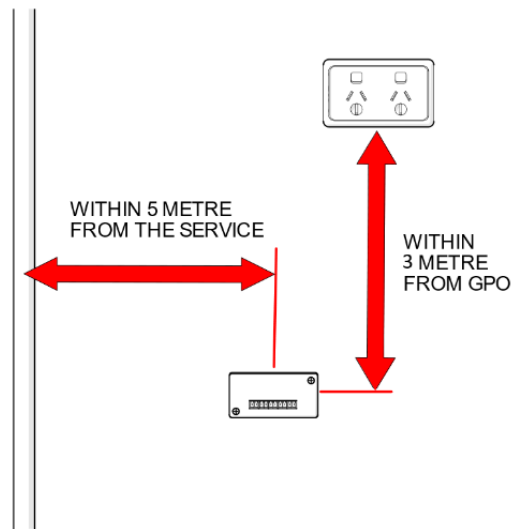

**Note: Controller must be mounted away from any moisture or potential water splashing.**

### 4. Mount control module

- Attach the control module to a flat surface away from any possible splashing or moisture using supplied Velcro.
- Find a suitable place to mount the control module within 5mtrs of the service and 3mtrs of the GPO.

**⚠ All electrical components should be protected from contact with water or excessive heat and installed in accordance with local regulations.**

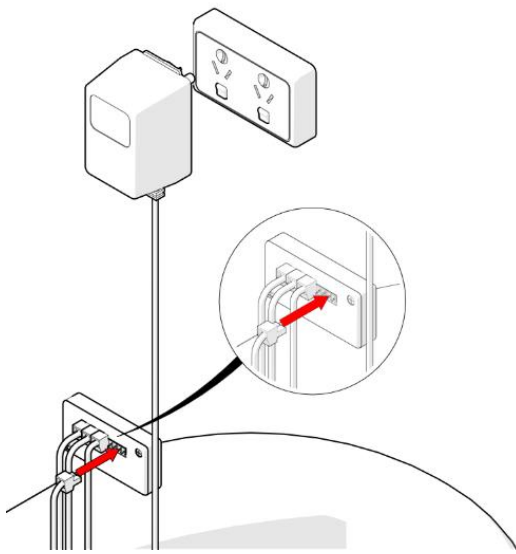

Typical Installation

**5. Control module connections**

- We recommended that all cabling is fed through 25mm conduit to make servicing and replacement easier.
- Connect the button leads to the input side of the control module and the solenoid leads to the output side.
- If extension leads are required, please contact Galvin Engineering.

**⚠ Do not cut the leads. If the leads are too long, it is recommended that any excess is coiled up and clipped to the wall.**

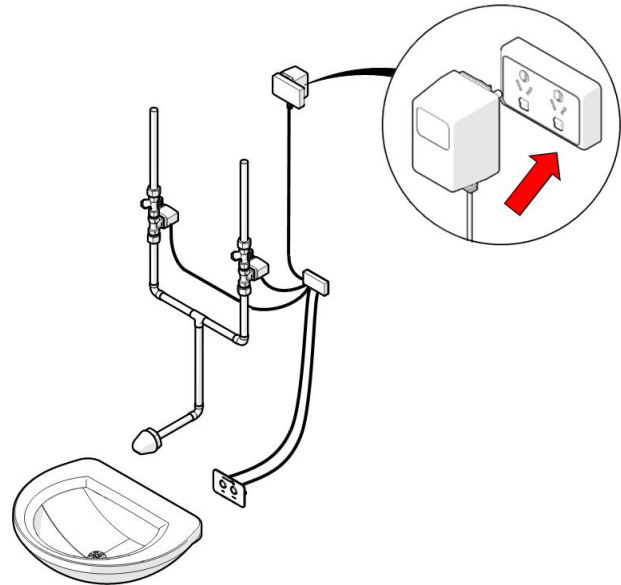

Typical Installation

**6. Connect power supply and check for correct operation**

- Connect the module to the GPO and turn on.
- When the button is pushed water should flow from the outlet
- Check for correct operation.

**⚠ The connection of this product to mains power supply should be undertaken by a competent person and should confirm to local Wiring Regulation – AS3000 Wiring rules.**

**CONTROL MODULE PROGRAM MODIFICATION**

**Required to make changes to the controller settings:**

- Android device (e.g. smartphone, tablet).
- Installed from PlayStore 'Flowmatic system' software.

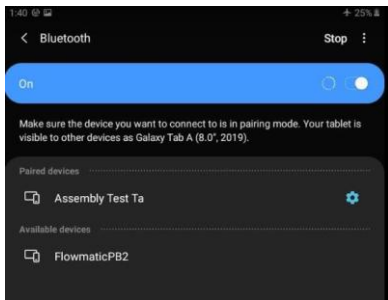
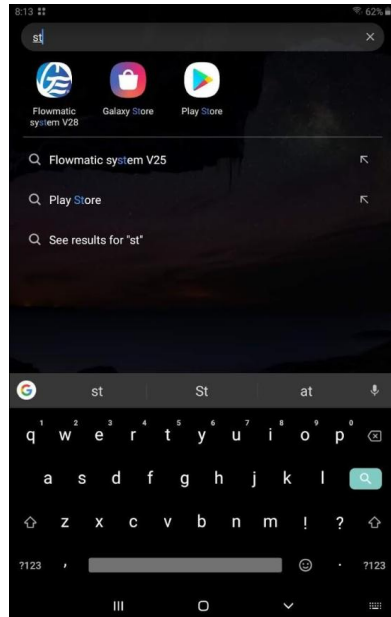

**1. Establish Bluetooth connection**

- Go to the Bluetooth settings on your device then scan for devices. Generally, when scanning the first thing to come up in available devices will be a Mac address that looks like this example (AB:EC:69:57:34:02). This will eventually change to the name of the device, which is from factory set as 'FlowmaticPB2' (This later can be changed to a custom name in the app). Select this device.

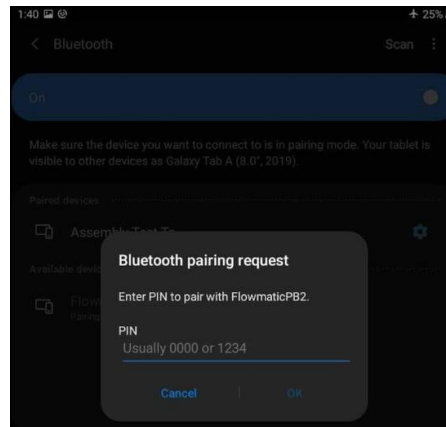

**2. Entering the pin**

- The device will ask for a pin, which from factory is '1234'. Enter this in. (This pin can be changed later in the app.). Your device is now connected to the controller, and is ready to be adjusted from the 'Flowmatic system' app.

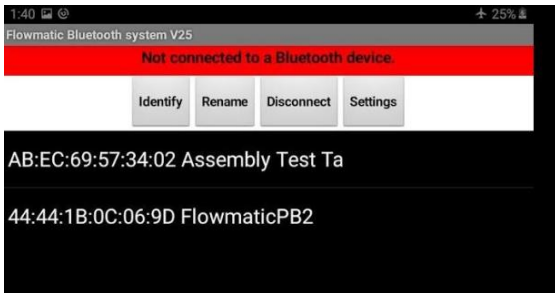

### 3. Changing controller settings

- Open the Flowmatic system' app. The device will appear on the screen. with Mac Address first and then controller name e.g. 'AB:EC:69:57:34:02 FlowmaticPB2'.
- Select the Flowmatic PB2, this will then update the controllers time clock, and then open the setting screen.

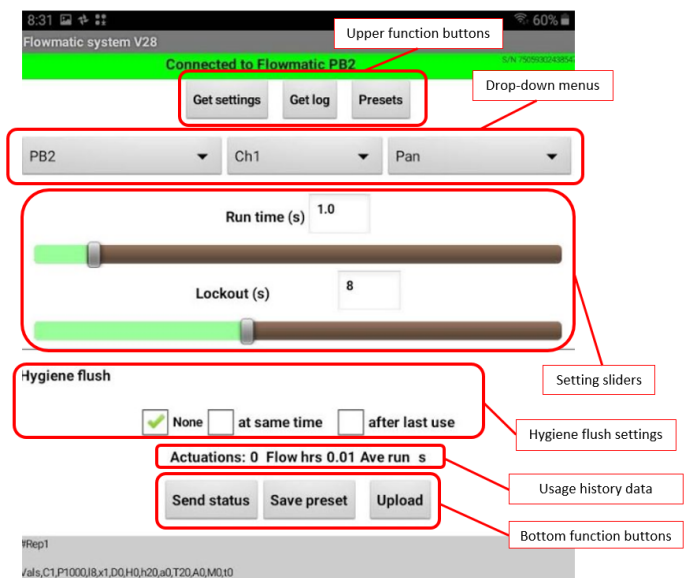

### 4. Setting screen overview.

- **Upper function buttons.** By pressing the 'Get settings' button the currently stored in controller's internal memory parameters will be downloaded to the app. The 'Get log' button will pop up the log data screen. The 'Presets' button will list all saved presets.
- **Drop-Down menus.** First menu from left is to select the type of controller the app is connected to. The second menu is to select which 'channel' is going to have parameters changed. The third menu is to declare what is the controlled feature designed for.
- **Setting sliders.** Depending on the selected controlled feature there will appear one, two or three setting sliders.
- **Hygiene flush setting** menu allows to set the time and intervals of hygiene flush.
- **Bottom function buttons** are to be used to manage the controller internal memory.

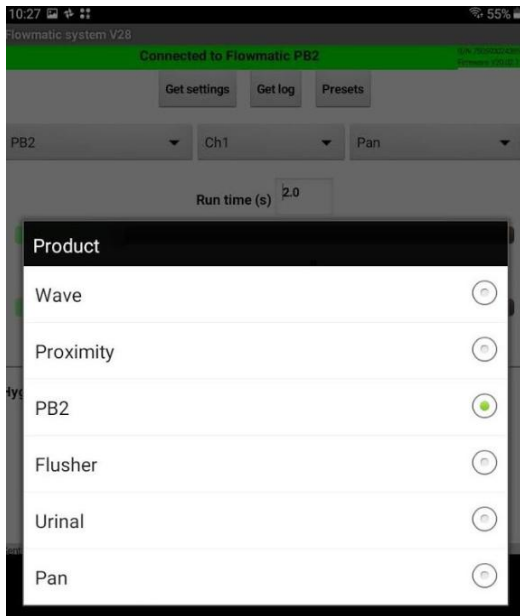

**5. Type of controller (left drop-down menu)**

- For the PB2 controller only the PB2 selection is correct. Please do not change the selection for the PB2 controller

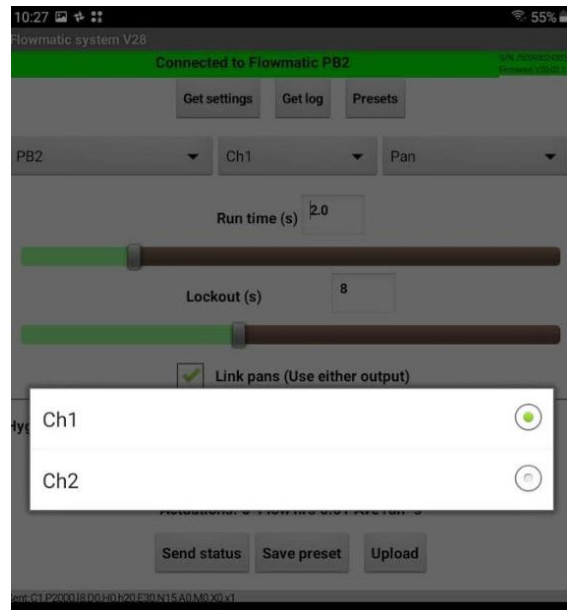

**6. Channel select (middle drop-down menu)**

- The PB2 controller has built in two channels. They may be controlled independently or one of the channels to be used as half flush and second channel as full flush for a pan.

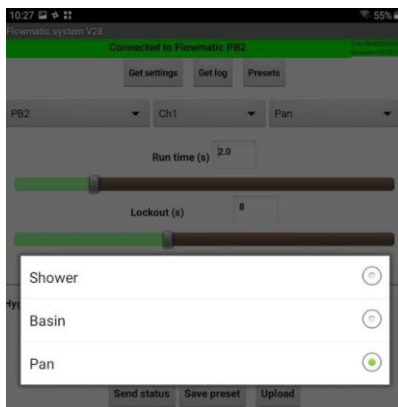

**7. Designated feature drop-down menu**

- The PB2 controller can be used for showers, basins and pans. Depend on the feature selection setting slides will appear. (e.g. there is only 'Run' time to be set for basin, 'Run' and 'Lockout' times for pans and there is 'Shower end warning' time for shower)

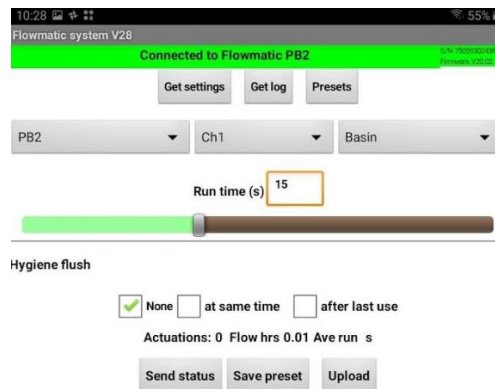

**8. Settings for Basin**

- Set the channel no. of the solenoid and activation button to be changed.
- Set the required water flow 'Run time' in seconds for the basin.
- Set the Hygiene flush parameters if required.
- Press 'Upload' to upload the settings to the controller.
- The controller can be used in configurations: one button – one solenoid, one button – two solenoids or two buttons – two solenoids.



**9. Settings for pans.**

- The default configuration for a pan is two buttons and one or two solenoids. By marking the 'Link pans' the outputs will work simultaneously.
- Chanel 1 is to be used for the half flush and the channel 2 for full flush.
- Set the required time and Hygiene flush for half flush (channel 1) and press 'Upload'.
- Similarly set the required time and Hygiene flush for full flush (channel 2) and press 'Upload'.

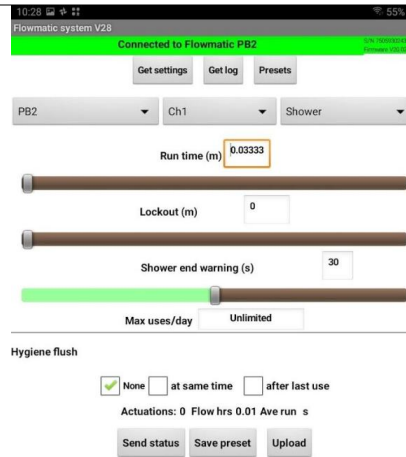

**10. Settings for shower.**

- PB2 controller is capable of controlling two buttons and two showers (solenoids).
- Select channel to be changed.
- Select desired 'Run time'.
- Select desired 'Lockout time' if required or set to "0" if not.
- Select 'Shower end warning'. Recommended only if setting a lock out time.
- Press 'Upload' to store the settings in the controller.

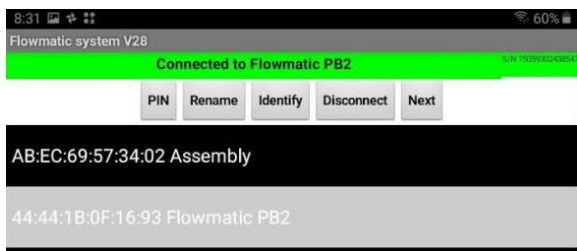

**11. Connection menu.**

- By pressing the back arrow on Android device, the connection screen will pop up.
- The buttons allow to rename the controller, set new PIN, disconnect or go to setting screen 'Next'.

TROUBLE SHOOTING		
PROBLEM	CAUSE	RECTIFICATION
No water flow	No power	Check power is reaching transformer
	Faulty solenoid valve	Check electrical connections, Replace solenoid valve
	Water or structural damage to electrical components	Replace damaged electrical components
	Incorrect connections	Check all connections
	Damage to sensor lead or power supply lead	Check and replace lead & controllers
	Pressure exceeding 500kPa	Reduce pressure to solenoid to 350 kPa
	Water corroded electrical connections	Replace electronic components
Continuous water flow	Solenoid valve jammed open	Remove obstruction from solenoid valve
	Solenoid installed incorrectly	Reinstall valve correctly

## Maintenance Instructions

### Solenoid Valve:

- Turn the water supply off and activate the push button to drain as much water from the installation as possible, and then turn the power off at the GPO.
- Depending on the location of the solenoid valve it may be more convenient to remove the solenoid valve completely from the installation to service it.
- The solenoid may be disassembled and checked for debris and cleaned to avoid potential damage to the diaphragm. Please take note of the location of the components and reassemble in the correct order, as there is a spring in the housing that may inadvertently spring out.
- Service or replace the solenoid and re-install into the line. Push the power plug from the sensor back onto the solenoid.
- It is recommended that the line strainer be serviced and cleaned at this stage to ensure that dirt and grit is not restricting the flow.
- Ensure the bypass tap on the valve is in the closed position.

### Push Button, Face Plate, Control Module and Power Transformer

These items are non-serviceable products. If damaged, they must be replaced.  
If there appears to be any problems with these items, please contact Galvin Engineering.

**Note: Before attempting to replace any of these items check that you have access to re-run the connection leads. If you do not have access or you have any doubts, please contact Galvin Engineering for advice before commencing replacement.**

## WARRANTY

Galvin Engineering products are covered under our Manufacturer's Warranty. Galvin Engineering products must be installed in accordance with the installation instructions and in accordance with AS/NZS 3500 and NCC Volume Three, relevant Australian Standards and local authorities applicable to product being installed. Water and electrical supply conditions must also comply to the applicable national and/or state standards, failing to comply with these provisions may void the product warranty and affect performance of the product.

Please visit [www.galvinengineering.com.au](http://www.galvinengineering.com.au) to view the full warranty, our Installation Compliance and Maintenance & Cleaning information as well as any other additional information.

## DEFINITIONS AND DISCLAIMER

Galvin Engineering manufactures a range of products marked as Ligature Resistant or Vandal Resistant. Please visit [www.galvinengineering.com.au](http://www.galvinengineering.com.au) to read the definition of these terms and the disclaimer that applies to these products.