

Product Installation Guidelines & Scope of Use

Version 1.3, 25 September 2025, Page 1 of 16
Document No: TZ-FLOWTMSHWDT

GalvinCare® Ligature Resistant Electronic Ducted Ezy-Grip Shower Mixer with Soap Holder and Controller

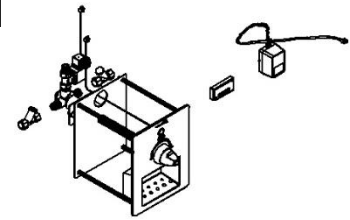

PRODUCT CODE:

- TZ-FLOWTMSHWDT

SPECIFICATIONS

- GalvinCare® shower assembly provides the complete ligature and vandal resistant solution. The unique electronic valve assembly provides a precise delivery of water, and is specifically designed for High risk and Secure environments.
- The adjustable temperature control Ezy-Grip handle allow users to adjust from cold to the set hot water temperature.
- 4mm thick, exposed stainless steel faceplate to suit back mounted applications and featuring push activation buttons. Faceplates have no front penetrations and are fixed from the duct.
- Solenoid is a Watermarked high flow, low-pressure loss control valve. The body is made from stainless steel and is hammer resistant.
- GalvinCare® Electronic controller is a 24V AC electronic control system allowing connection of up to 2 button inputs and up to 2 solenoids (single solenoid only for flushing units). Controller is pre-programmed and ready to use. The solenoids will open for a specific time once the appropriate button is pressed. The standard program can be modified to suits individual needs. To modify the operation settings a compatible Android device with Bluetooth is required.

TECHNICAL DATA

Power Supply	Type	Transformer	
	Input	230-240V – 50Hz	
	Output	24V AC 0.9AMPS 22VA	
	Cable length	3m	
Solenoid	Input Voltage	24V AC – 50Hz	
	Power Consumption	8W	
	Cable length	5m	
Sensor	Type	IP68 24V	
	Activation	Push Button	
	Connections	2 pin connector	
	Cable length	5m	
Controller	Input Voltage	24V AC	
	Program type	Flowmatic	
	Connections	2 pin connectors	
Connections	Outlet	1/2" BSP - Female	
	Inlets	1/2" BSP - Male	
Supply Water Conditions	Pressure Range (kPa)	Min	100
		Max	500
	Temperature (°C)	Min	5
		Max	90
Finish (user)	Stainless Steel		
NOTE: Galvin Engineering continually strive to improve their products. Specifications may change without notice.			
WARNINGS: Special attentions to be paid on notes, photos, images, or drawings of assembly steps marked with the warning symbol.			

PRE - INSTALLATION

IMPORTANT:

- **INSTALLATION COMPLIANCE:** Galvin Engineering products must be installed in accordance with these installation instructions and in accordance with AS/NZS 3500, the PCA and your local regulatory requirements. Water and/or electrical supply conditions must also comply to the applicable national and/or state standards. Failing to comply with these provisions shall void the product warranty and may affect the performance of the product (Refer to installation compliance sheet supplied with the product).
- Before proceeding with installation first check the solenoid valve supplied is suitable for the site water pressure and conditions. If your water pressure is outside the stated range, please contact Galvin Engineering.
- Ensure all supply lines are flushed thoroughly to remove debris prior to the installation of this product. A line strainer is supplied to protect the solenoid valve from debris.
- We recommend a thermostatic mixing valve is used to provide premixed water to the valve and a pressure reduction valve may be required to comply with recommended maximum supply pressure.
- Ensure that access to the push button, solenoid valve and transformer/GPO is available for future maintenance when installing the components. It is recommended that isolating valves be installed upstream to the solenoid valve to allow for servicing. All wiring must be able to be removed when installed into cavities or walls, therefore, it is recommended that a minimum of 25mm conduit be used to house the leads. The unit is supplied with 3 meters of lead on the transformer and a 5-meter lead from the solenoid. Additional lead lengths may be accommodated up to a length of 5m but must be ordered separately.
- Whilst our product designs take into account a broad range of installation types and surfaces, it is important that surfaces which fixtures are mounted to are flat and free from defects. Additionally, ensure any protruding connecting thread is square to the wall so that the outlet sits flat against the wall when installed, ensuring that there are no gaps between the wall and outlet. This is especially important when installing product ranges that have been designed for correctional and health facilities, where special attention is required to minimise ligature points and areas for concealment of contraband. In addition to ensuring the products are fitted securely and in accordance with the following instructions, consideration shall be given to the use of non-pick mastics such as BASF Sonolastic "Ultra" to ensure a high quality and safe installation.
- Most installation problems are due to damage to the unit during installation or the selection of an inappropriate installation location. Select the location carefully and take care with the installation, consider ease of operation for the end user.

GENERAL INSTALLATION REQUIREMENTS

- Do not cut the wires or extend the existing leads without using a correct lead extension from Galvin Engineering, as this will void warranty.
- Suitable access to the service of all components must be provided.
- It is recommended that acoustic dampening products or materials be used in facilities where increased levels of sound protection are required. A water hammer arrestor may also be required.
- The number of valves and simultaneous demand must be considered when sizing pipes. If other fixtures are connected to the supply line, calculations of flow rates and pressures must be undertaken to ensure adequate water supply.
- Limit the number of changes of directions in pipe work. This will result in less friction loss, better valve performance and reduce potential water cavitation noise.
- We recommend fitting isolating valves before solenoid for easy servicing.
- Do not apply heat near this product during connecting water lines. Heat generated by soldering could damage plastic or electrical parts and seals and will void the warranty.
- For personal installation assistance and spare parts, please call our head office on 1300 514 074 and speak to our customer service staff.

Mounting Details

Shower face plate position

- Locate the shower face plate at a suitable distance from the shower rose (we recommend the shower face plate is not positioned directly beneath the shower rose, but at 300mm to the right or left of the centre line of shower rose and at a height of 1200mm from floor level to the centre of the Ezy-Grip handle).
- Outlets are not supplied and must be ordered separately. E.g., 40691(std) / 40698 (duct)

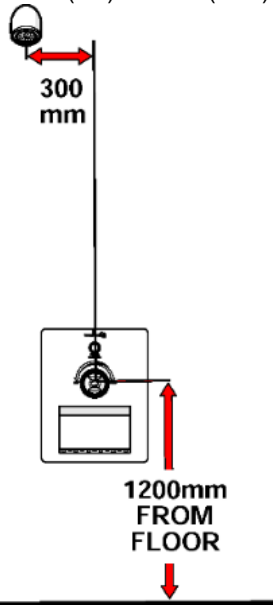

Cut out details for face plate

- Shower assembly to suit wall thickness between 75mm to 240mm. Ensure the cut out details are as below, and the wall thickness does not exceed 240mm.

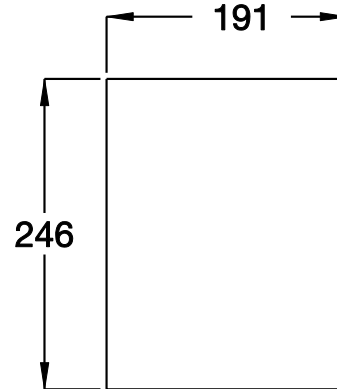

Component Dimensions

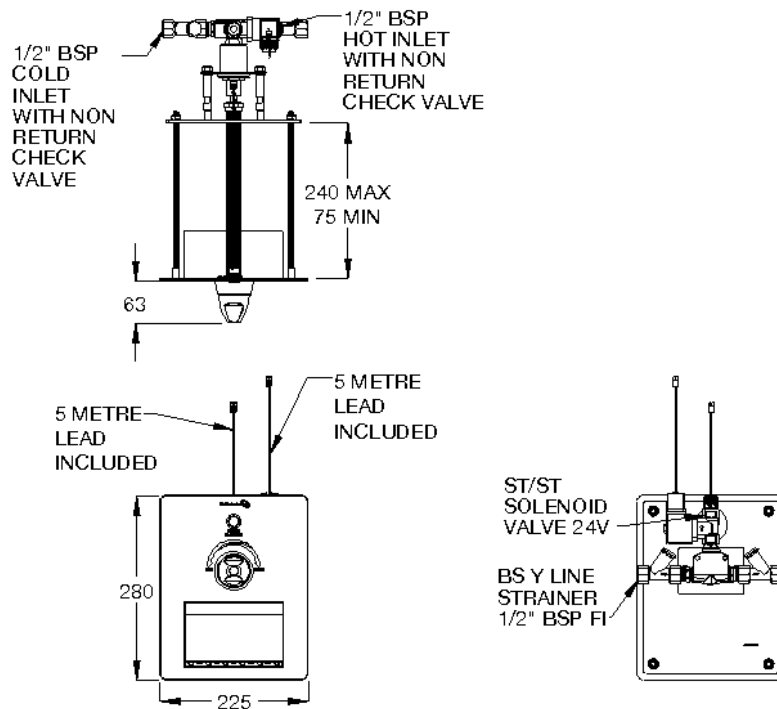

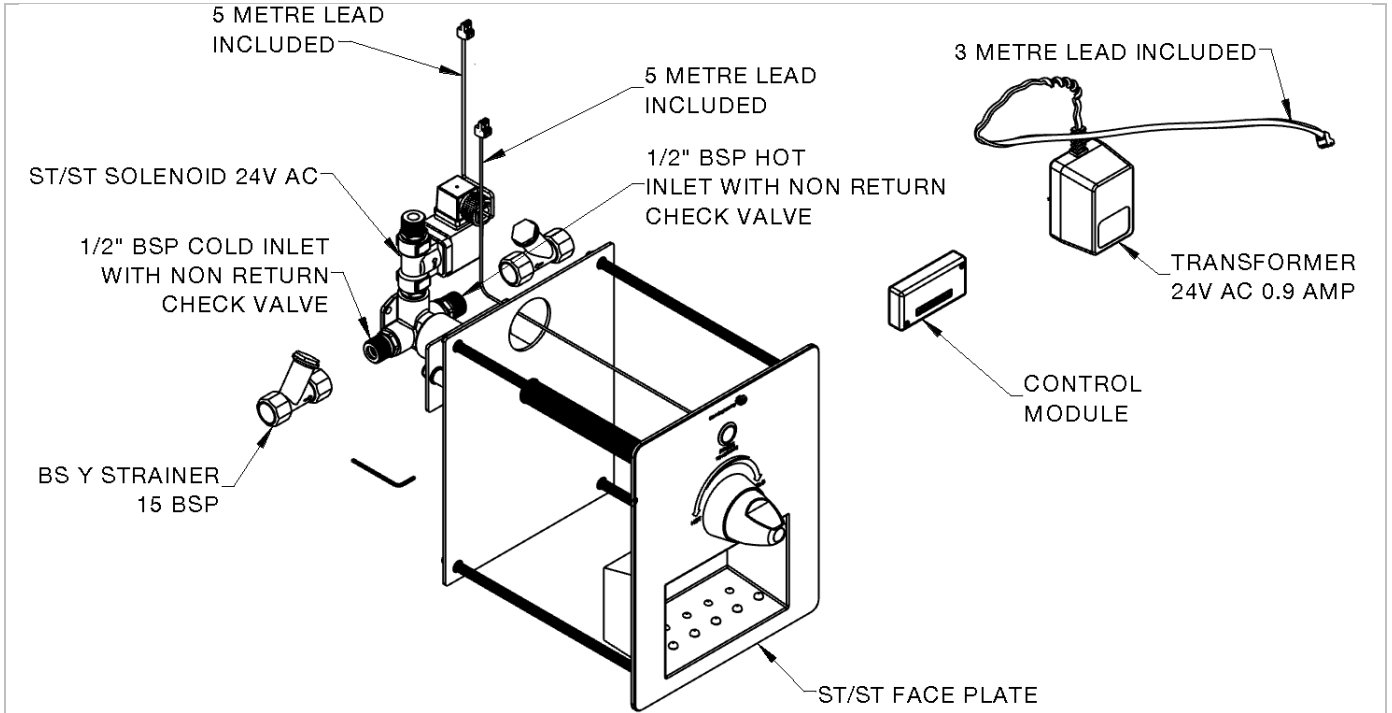

INSTALLATION

⚠️ Avoid common installation errors :

- Incorrect supply pipe size installed.
- Non-compliance to Australian Standards.
- Water pressure not tested before installation
- Lines not flushed before installation.
- No access for service.
- Valve not commissioned properly.

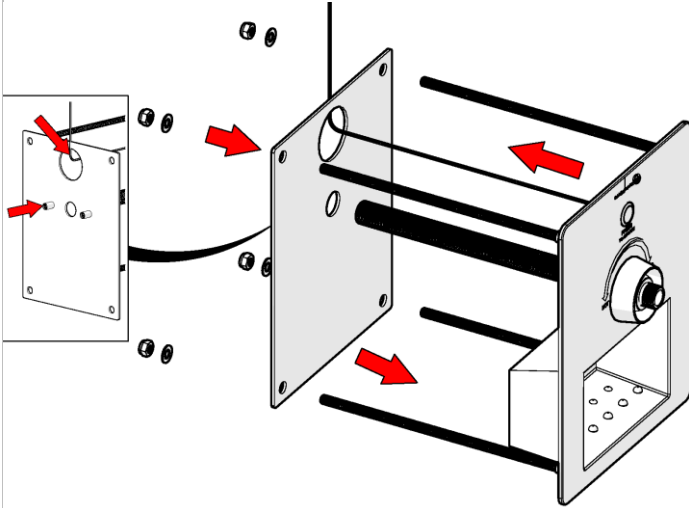

1. Mount faceplate

- The stainless steel faceplate is always mounted flush to the wall.
- Mount faceplate to the wall using the backplate, washers and nyloc nuts; the two welded nuts on the backplate must be outside the wall cavity.
- Ensure the button lead is fed through the large hole at the top of the backplate and lightly tighten with the nyloc nuts until the assembly is held
- Apply a thin bead of silicon on the edge of the wall cut out.

⚠️ **Do not force the faceplate to fit onto wall or attempt to disassemble components, as this could result in damage to sensor push button.**

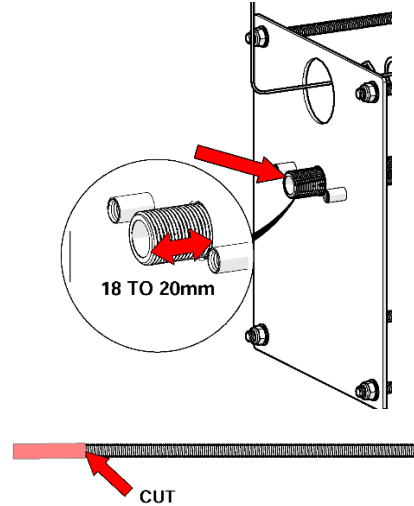

2. Shorten tail

- Before tightening the Nyloc nuts, check that the threaded tail protrudes past the back plate between 18-20mm. If it is too long mark the threaded tail, remove the back plate and cut to suit.

Note: if the 4 threaded studs are too long these can also be shortened to suit.

⚠️ **Warning:** remove the centre Ezy-Grip handle before shortening. De-burr the threaded tail after cutting and re-assemble into wall. Do not over tighten Nyloc nuts (max. 35 Nm).

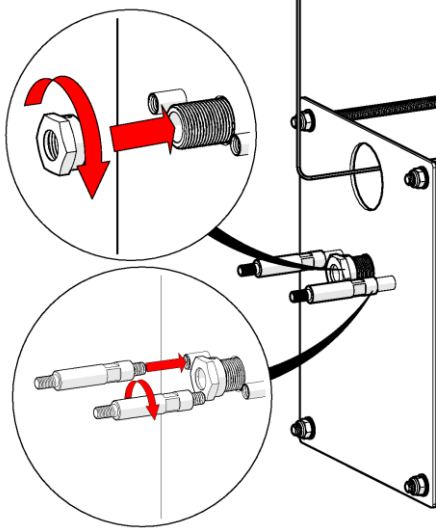

3. Fit guide nut and studs

- Fit the guide nut to the end of the extension tail and tighten.
- Fit the two brass studs into the welded nuts on the backplate and tighten

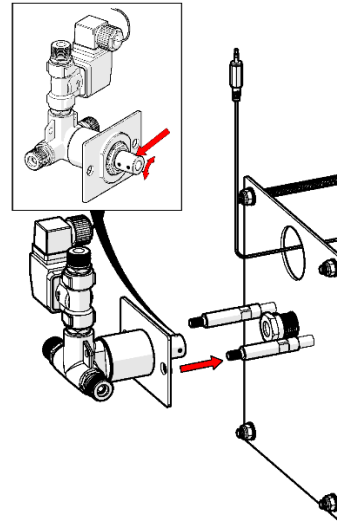

4. Adjust diverter

- Turn the shower diverter from one extreme to the other, this should be 90° of movement.
- Set the diverter cartridge midway of the movement (45°). In this position the drilled hole in the brass connector should be vertical; this will allow easy drilling of handle

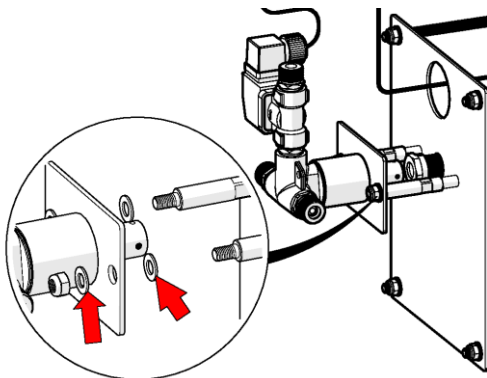

5. Fit the solenoid assembly

- Fit the solenoid assembly onto the brass studs with washers on both sides of the mounting plate as shown, lightly tighten with the nyloc nuts until the assembly is held

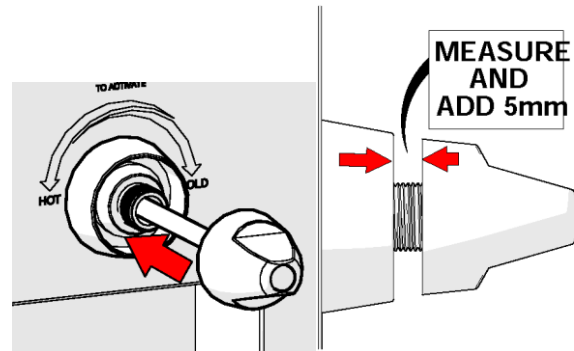

6. Adjust handle length

- Insert the Ezy-Grip handle through the threaded tail and into the brass connector on the mounted solenoid assembly making sure the Ezy-Grip handle is pushed as far into the brass connector as it will go.
- Measure the distance from the underside of the Ezy-Grip handle to the top of the flange and add 5mm. This is the amount that the Ezy-Grip handle needs to be shortened by.
- Remove the Ezy-Grip handle and mark this distance from the end of the shaft and cut, remove any burrs

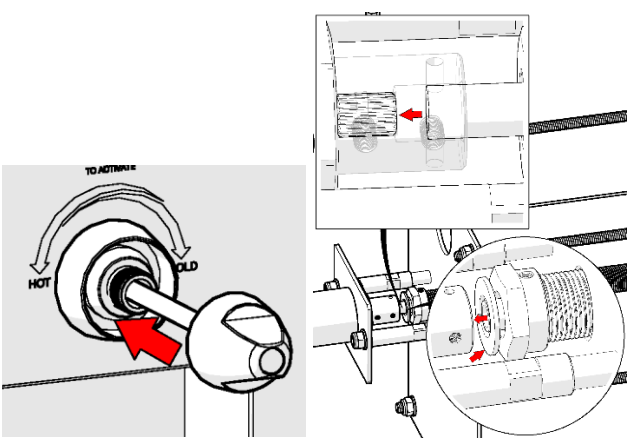

7. Re-assemble handle

- Re-insert the Ezy-Grip handle through the threaded tail and the flat washer before entering the brass connector on the mounted solenoid assembly.
- Ensure the Ezy-Grip handle is sitting correctly in the flange and is pushed as far into the brass connector as it will go.

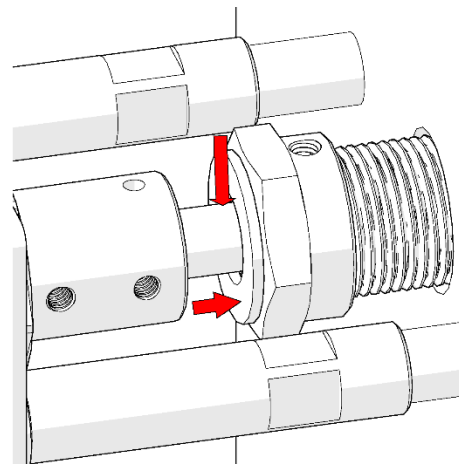

8. Mark shaft for cotter pin

- Hold the flat washer against the guide nut and mark the shaft 2mm from the face of the washer.
- Remove the extended handle and drill a $\text{\O}3$.mm hole through the shaft where marked.
- Re-insert the extended handle through the extension tail and the flat washer before entering the connector on the mounted solenoid assembly.

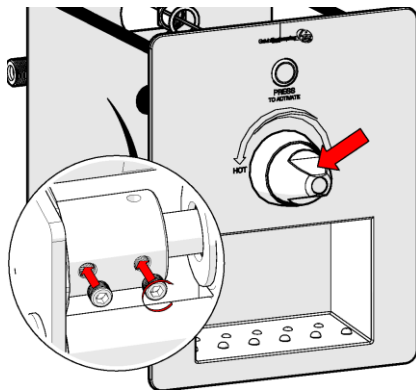

9. Set handle position

- Adjust the Ezy-Grip handle so the flats are horizontal.
- Fit the supplied grub screw into the brass connector and lock the handle.
- Check the handle alignment to the solenoid movement is correct. If it is not, loosen the grub screw and adjust before re-tightening.

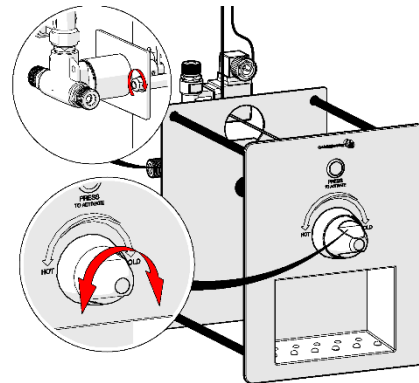

10. Tighten solenoid assembly

- Check the handle moves freely and the flats on the handle are horizontal midway through the handles movement (if the movement appears to be very tight or sticks loosen the nyloc nuts holding the solenoid assembly and move around on the clearance of the holes until easy movement is achieved).

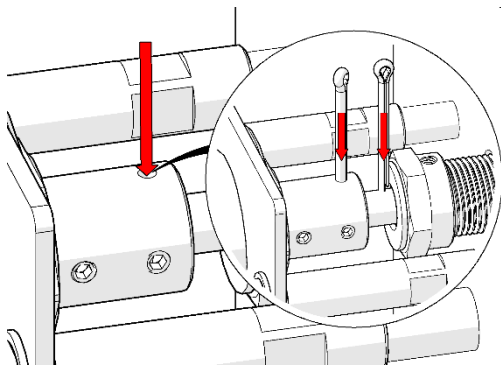

11. Lock handle

- Using the hole in the brass connector drill a Ø3.0mm hole through the shaft of the Ezy-Grip handle
- Fit the cotter pins through the brass connector and Ezy-Grip handle shaft; bend over the ends to stop the cotter pin falling out in use

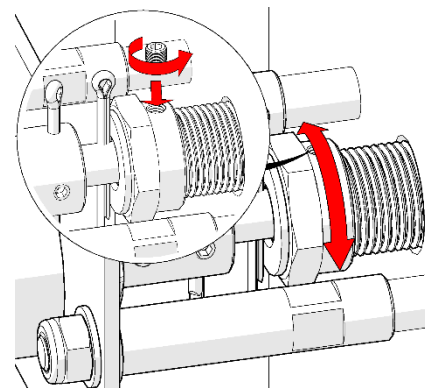

12. Adjust handle end float

- Adjust guide nut to limit end float on the handle, do not over tighten as it will affect the easy use of the handle.
- Once the end float has been adjusted lock the guide nut in position with the supplied grub screw.

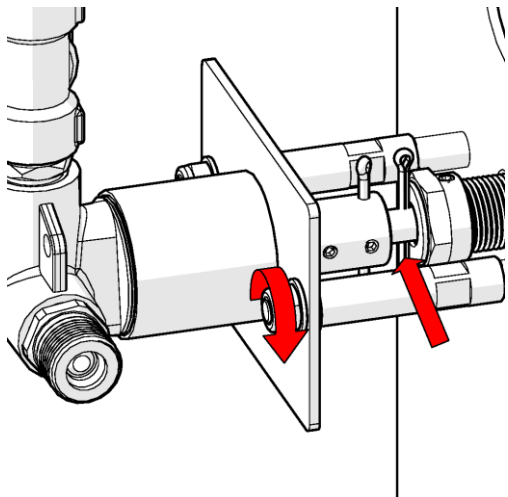

13. Check nut, screws and pins

- Ensure all nyloc nuts and grub screws are securely tightened (max. 35 Nm) and the cotter pins have been bent over to stop them falling out.

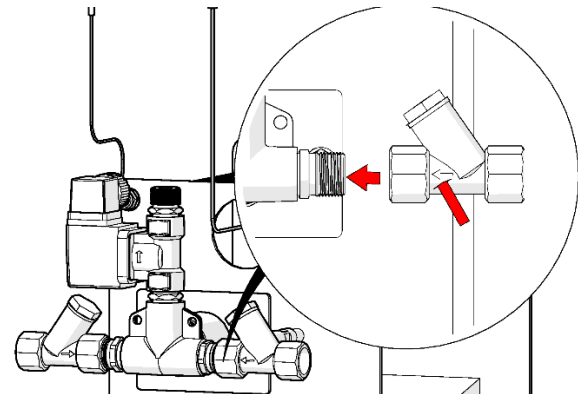

14. Fit Y strainers

- The supplied Y strainers are fitted in line. Ensure they are installed in the correct direction (the arrow on the Y strainer body must align with the direction of water flow).
- Not using these strainers may void the warranty

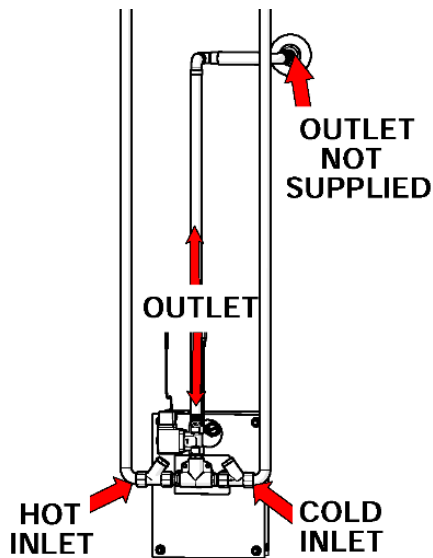

15. Connect water supply and outlet

- Connect the water supply to the inlet check valves and the shower rose (not supplied) to the outlet on top of the solenoid assemblies. Turn on water supply and check for leaks.

Note: The TZ-FLOWTMSHWDT is not supplied with our GalvinCare® vandal resistant shower rose - Item# 40691/40698 and must be specified at time of order

⚠ Do not apply heat near this product. Heat generated by soldering could damage plastic or electrical parts and seals and will void the warranty.

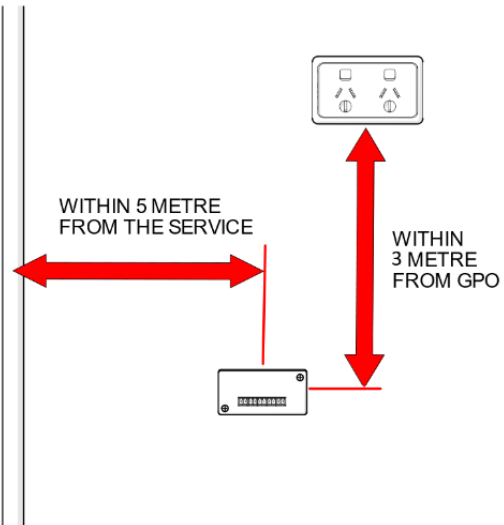

Note: Controller must be mounted away from **⚠ any moisture or potential water splashing.**

16. Mount control module

- Attach the control module to a flat surface away from any possible splashing or moisture using supplied Velcro.
- Find a suitable place to mount the control module within 5mtrs of the service and 3mtrs of the GPO.

⚠ All electrical components should be protected from contact with water or excessive heat and installed in accordance with local regulations.

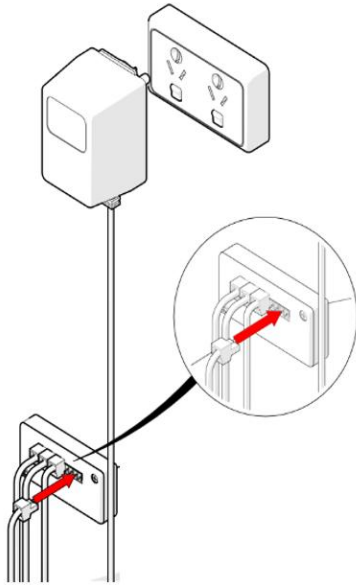

17. Control module connections

- We recommended that all cabling is fed through 25mm conduit to make servicing and replacment easier.
- Connect the button leads to the input side of the control module and the solenoid leads to the output side.
- If additional extension leads are required please contact Galvin Engineering.

⚠ Do not cut the leads. If the leads are too long, it is recommended that any excess is coiled up and clipped to the wall.

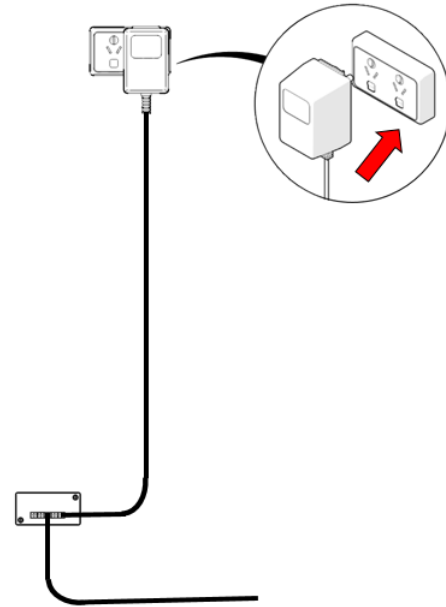

18. Connect power supply and check for correct operation

- Connect the module to the GPO and turn on.
- When the button is pushed water should flow from the outlet.
- Check for correct operation.

⚠ The connection of this product to mains power supply should be undertaken by a competent person and should conform to local Wiring Regulation – AS3000 Wiring rules.

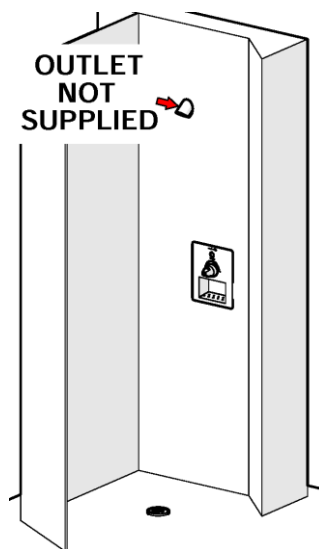

Typical Installation

CONTROL MODULE PROGRAM MODIFICATION

Required to make changes to the controller settings :



- Android device (e.g. smartphone, tablet).
- Installed software from PlayStore 'Flowmatic system'.

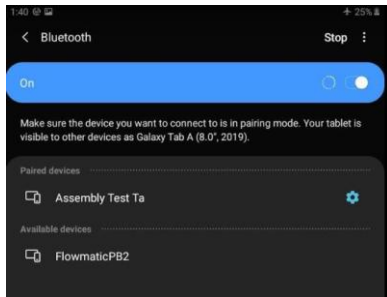
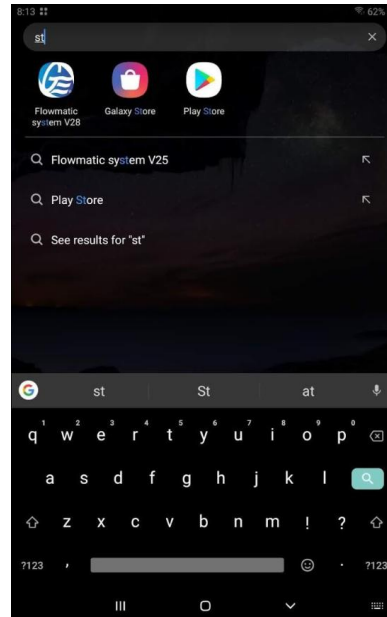

1. Establish Bluetooth connection

- Go to the Bluetooth settings on your device then scan for devices. Generally, when scanning the first thing to come up in available devices will be a Mac address that looks like this example (AB:EC:69:57:34:02). This will eventually change to the name of the device, which is from factory set as 'FlowmaticPB2' (This later can be changed to a custom name in the app).
- Select this device.

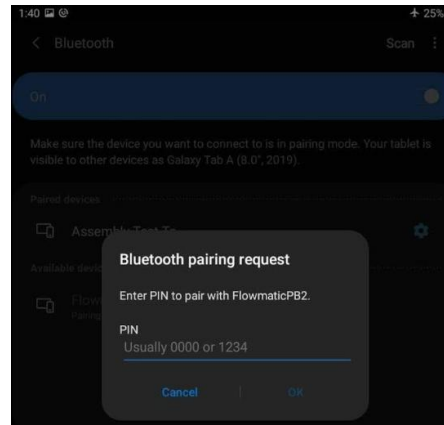

2. Entering the pin

- The device will ask for a pin, which from factory is '1234'. (This pin can be changed later in the app.). Your device is now connected to the controller, and is ready to be adjusted from the 'Flowmatic system' app.

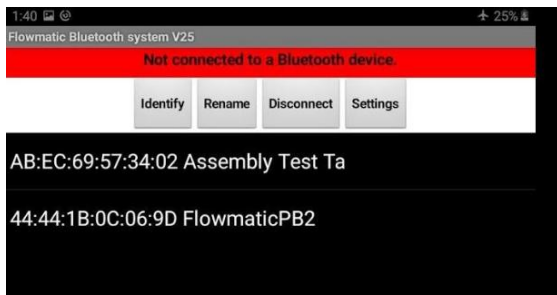

3. Changing controllers settings

- Open the Flowmatic system' app. The device will appear on the screen. with Mac Address first and then controller name e.g. 'AB:EC:69:57:34:02 FlowmaticPB2'.
- Select the Flowmatic PB2, this will then update the controllers time clock, and then open the setting screen.



4. Setting screen overview.

- **Upper function buttons.** By pressing the 'Get settings' button the currently stored parameters in the controller's internal memory will be downloaded to the app. The 'Get log' button will pop up the log data screen. The 'Presets' button will list all saved presets.
- **Drop-Down menus.** First menu from left is to select the type of controller the app is connected to. The second menu is to select which 'channel' is going to have parameters changed. The third menu is to declare what is the controlled feature designed for.
- **Setting sliders.** Depending on the selected controlled feature there will appear one, two or three setting sliders.
- **Hygiene flush setting** menu allows to set the time and intervals of hygiene flush.
- **Bottom function buttons** are to be used to manage the controller internal memory.

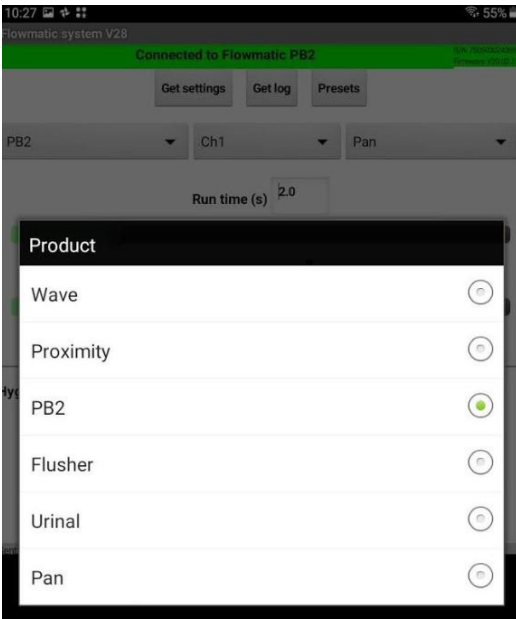

- 5. Type of controller (left drop-down menu)**
- For the PB2 controller only the PB2 selection is correct. Please do not change the selection for the PB2 controller

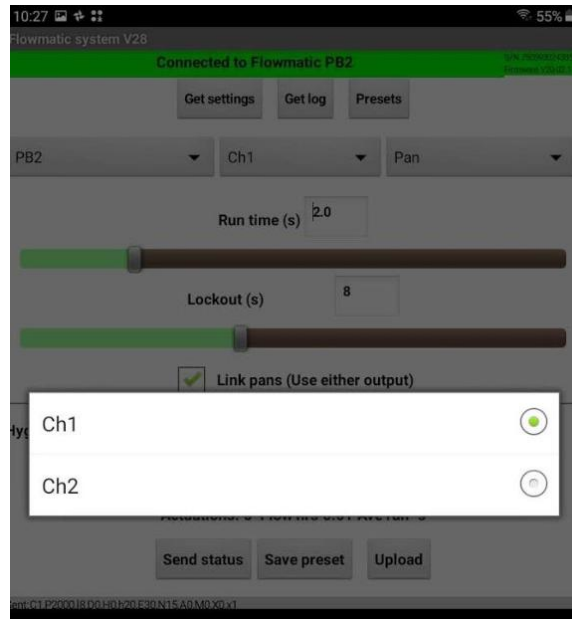

- 6. Chanel select (middle drop-down menu)**
- The PB2 controller has two built in channels. They may be controlled independently or one of the channels to be used as half flush and second channel as full flush for a pan.

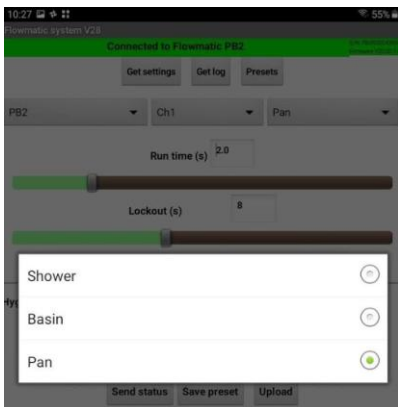

- 7. Designated feature drop-down menu**
- The PB2 controller can be used for showers, basins and pans. Depending on the feature selected setting sliders will appear. (e.g. there is only 'Run' time to be set for basin, 'Run' and 'Lockout' times for pans and there is 'Shower end warning' time for showers)

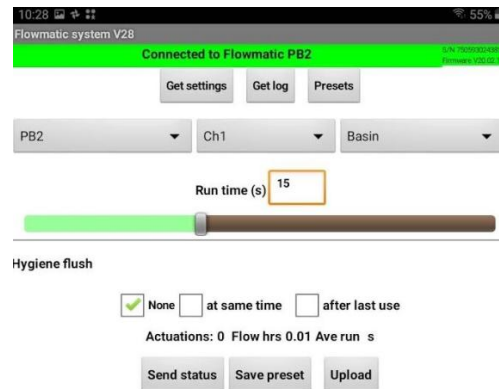

- 8. Settings for Basin**
- Set the channel no. of the solenoid and activation button to be changed.
 - Set the required water flow 'Run time' in seconds for the basin.
 - Set the Hygiene flush parameters if required.
 - Press 'Upload' to upload the settings to the controller.
 - The controller can be used in configurations: one button – one solenoid, one button – two solenoids or two buttons – two solenoids.

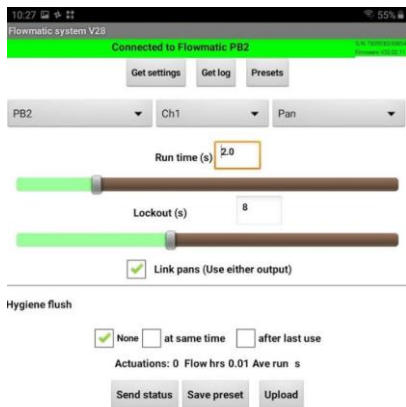

9. Settings for pans.

- The default configuration for a pan is two buttons and one or two solenoids. By marking the 'Link pans' the outputs will work simultaneously.
- Channel 1 is to be used for the half flush and channel 2 for full flush.
- Set the required time and Hygiene flush for half flush (channel 1) and press 'Upload'.
- Similarly set the required time and Hygiene flush for full flush (channel 2) and press 'Upload'.

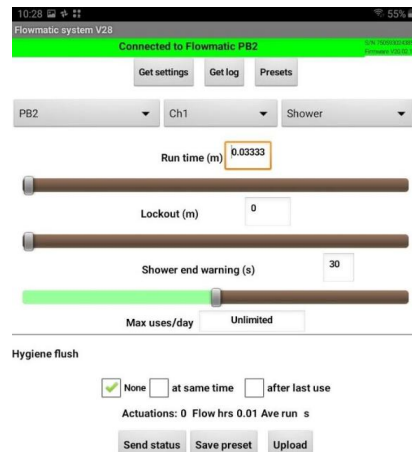

10. Settings for shower.

- PB2 controller is capable of controlling two buttons and two showers (solenoids).
- Select channel to be changed.
- Select desired 'Run time'.
- Select desired 'Lockout time' if required or set to "0" if not.
- Select 'Shower end warning'. Recommended only if setting a lock out time.
- Press 'Upload' to store the settings in the controller.

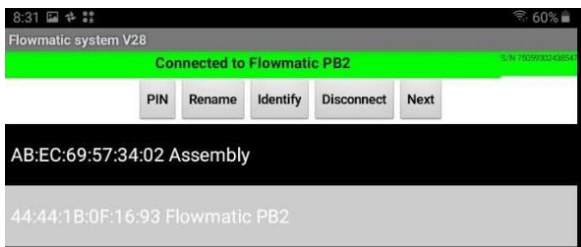

11. Connection menu.

- By pressing the back arrow on Android device, the connection screen will pop up.
- The buttons allow to rename the controller, set new PIN, disconnect or go to setting screen 'Next'.

Maintenance Instructions

Solenoid Valve:

- Turn the water supply off and activate the push button to drain as much water from the installation as possible, and then turn the power off at the GPO.
- Depending on the location of the solenoid valve it may be more convenient to remove the solenoid valve completely from the installation to service it.
- The solenoid may be disassembled and checked for debris and cleaned to avoid potential damage to the diaphragm. Please take note of the location of the components and reassemble in the correct order, as there is a spring in the housing that may inadvertently spring out.
- Service or replace the solenoid and re-install into the line. Push the power plug from the sensor back onto the solenoid.
- It is recommended that the line strainer be serviced and cleaned at this stage to ensure that dirt and grit isn't restricting the flow
- Ensure the bypass tap on the valve is in the closed position

Push Button, Face Plate, Control Module and Power Transformer

These items are non-serviceable products. If damaged they must be replaced.
 If there appears to be any problems with these items please contact Galvin Engineering.

Note: Before attempting to replace any of these items check that you have access to re-run the connection leads. If you do not have access or you have any doubts, please contact Galvin Engineering for advice before commencing replacement.

TROUBLE SHOOTING

PROBLEM	CAUSE	RECTIFICATION
No water flow	No power	Check power is reaching transformer
	Faulty solenoid valve	Check electrical connections, Replace solenoid valve
	Water or structural damage to electrical components	Replace damaged electrical components
	Incorrect connections	Check all connections
	Damage to sensor lead or power supply lead	Check and replace lead & controllers
	Pressure exceeding 500kPa	Reduce pressure to solenoid to 350 kPa
	Water corroded electrical connections	Replace electronic components
Continuous water flow	Solenoid valve jammed open	Remove obstruction from solenoid valve
	Solenoid installed incorrectly	Reinstall valve correctly
	Bypass valve lever on the solenoid in the 'open' position	Move the valve handle to the 'closed' position

WARRANTY

Galvin Engineering products are covered under our Manufacturer's Warranty. Galvin Engineering products must be installed in accordance with the installation instructions and in accordance with AS 3500 and NCC Volume Three, relevant Australian Standards and local authorities applicable to product being installed. Water and electrical supply conditions must also comply to the applicable national and/or state standards, failing to comply with these provisions may void the product warranty and affect performance of the product.

Please visit www.galvinengineering.com.au to view the full warranty, our Installation Compliance and Maintenance & Cleaning information as well as any other additional information.

DEFINITIONS AND DISCLAIMER

Galvin Engineering manufactures a range of products marked as Ligature Resistant or Vandal Resistant. Please visit www.galvinengineering.com.au to read the definition of these terms and the disclaimer that applies to these products.

Within Australia: 1300 514 074 Outside Australia: P: +61 (0)8 9338 2344

F: +61 (0)8 9338 2340

sales@galvinengineering.com.au

www.galvinengineering.com.au

ABN: 78 008 719 382

PERTH | SYDNEY | MELBOURNE | BRISBANE | ADELAIDE

